

MIMI D

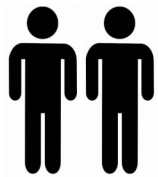
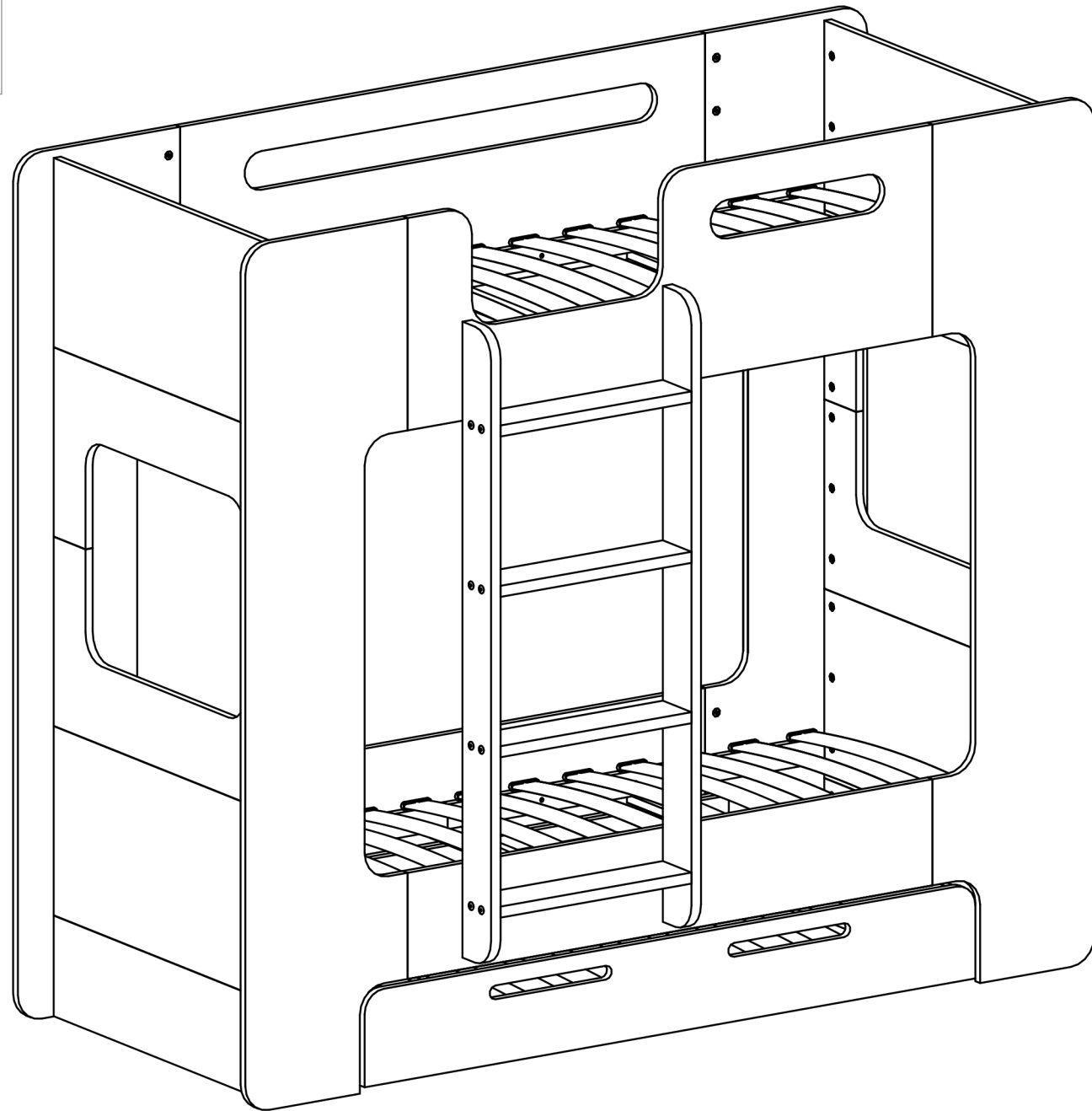

Recommended
assembly by 2 person

PLEASE READ BEFORE ASSEMBLY

- 1) Make sure there is enough free space for installation.
- 2) Before fully unpacking, please measure the elements whether they match the order.
- 3) After unpacking the elements from the boxes, please check the completeness of the set with the assembly instructions – if you find that something is missing – let us know and if necessary, we will send the missing parts.
- 4) Consider whether you will need help with assembly, if you find it necessary, find someone to help you.
(For bunk beds assembly, we recommend two people).
- 5) The installation of wooden dowels must be done on a solid, flat surface. By using a hammer in this process, remember not to use too much force.

REMEMBER!

NEVER HAMMER WOODEN DOWELS IN THE AIR OR WITHOUT SUPPORT!

RECOMMENDED ASSEMBLY TOOLS



K[]

HAMMER for DOWELS

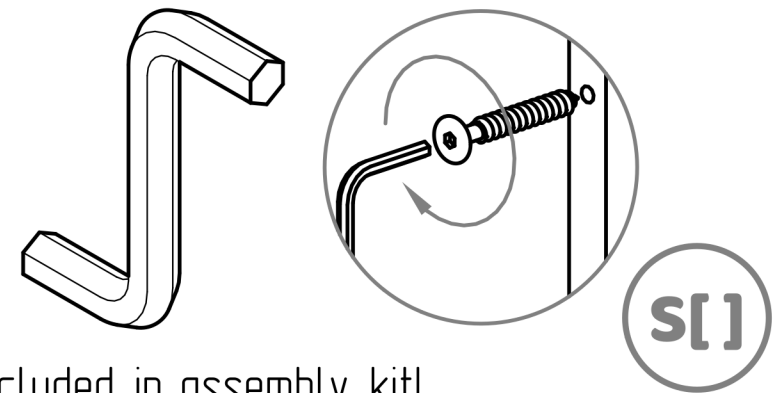

S[]

Included in assembly kit!

ALLEN KEY for SCREWS

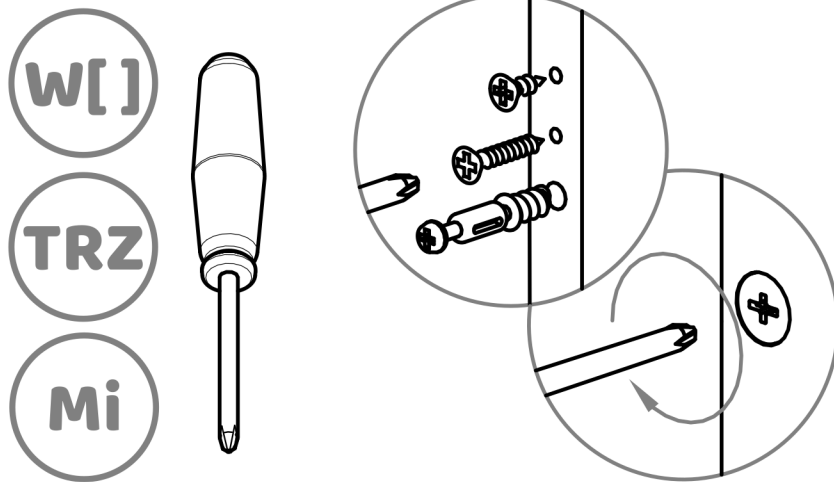

W[]

TRZ

Mi

SCREWDRIVER for
BOLTS & ECCENTRICITIES

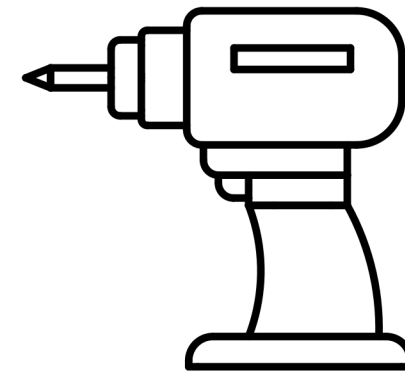

CORDLESS SCREWDRIVER

To avoid damaging furniture
use only low power mode

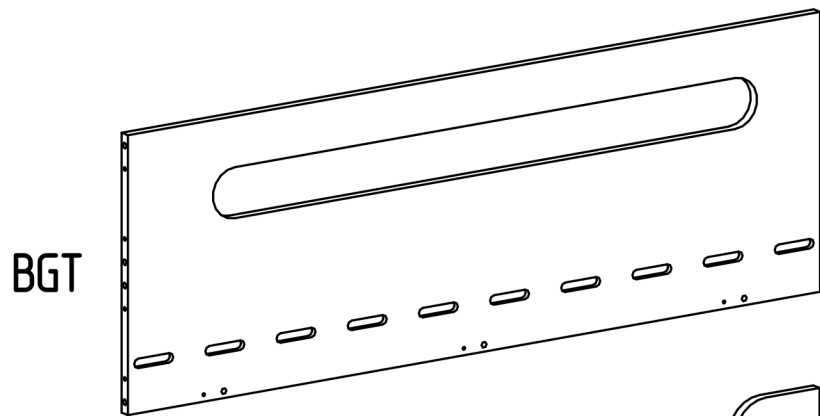

BGT

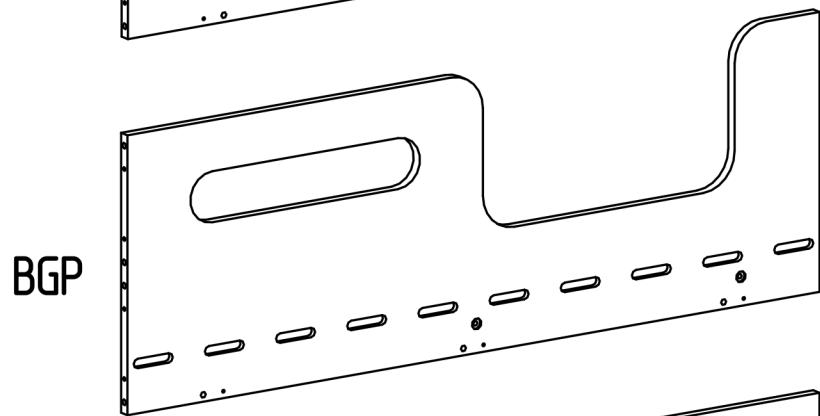

BGP

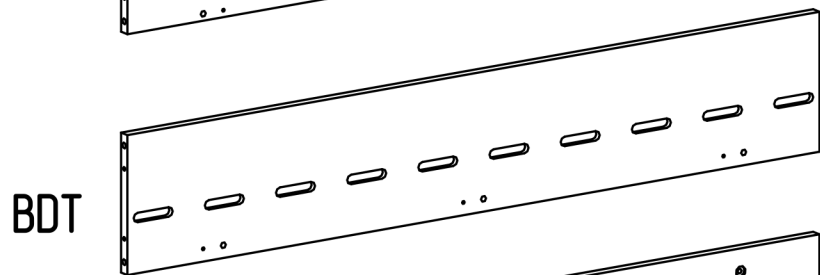

BDT

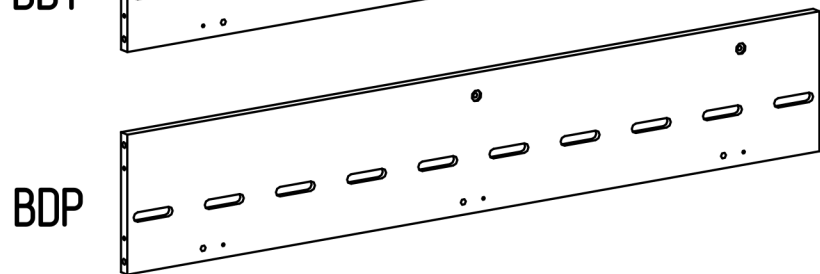

BDP

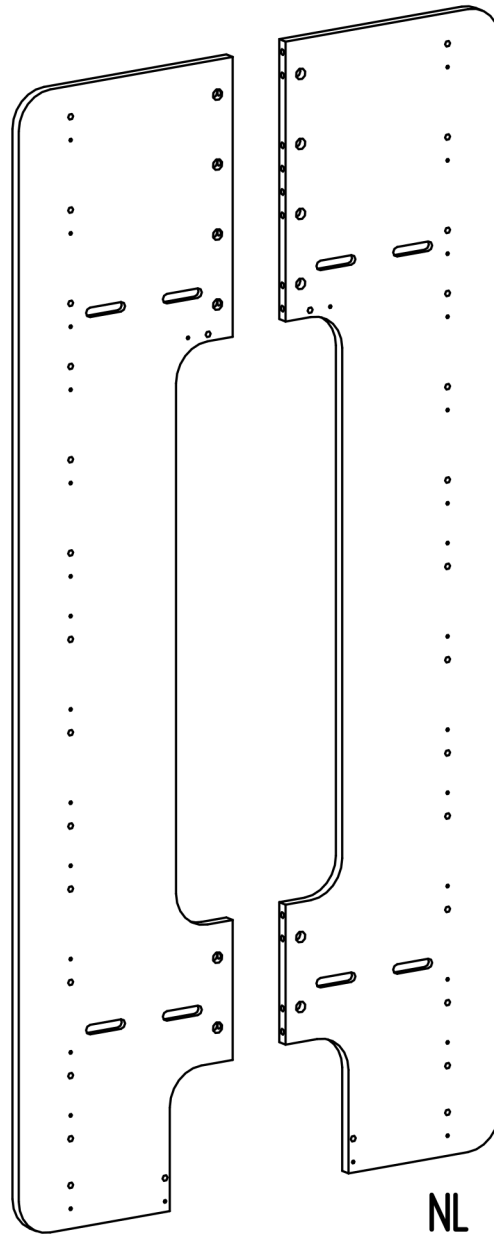

NP

NL

MIMI D

| | |
|-----|----|
| BGT | x1 |
| BGP | x1 |
| BDT | x1 |
| BDP | x1 |
| NP | x2 |
| NL | x2 |

Drawer elements are on page 13

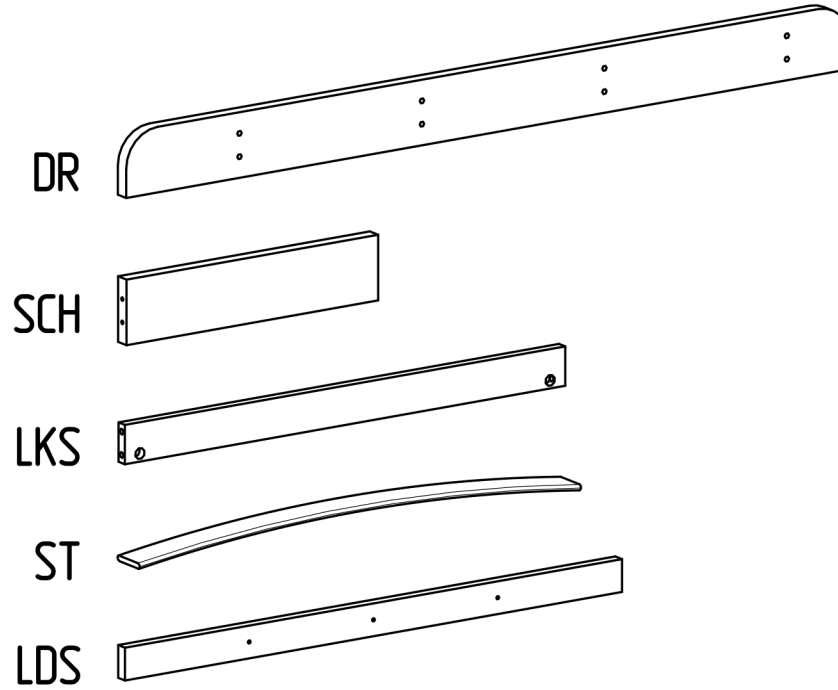
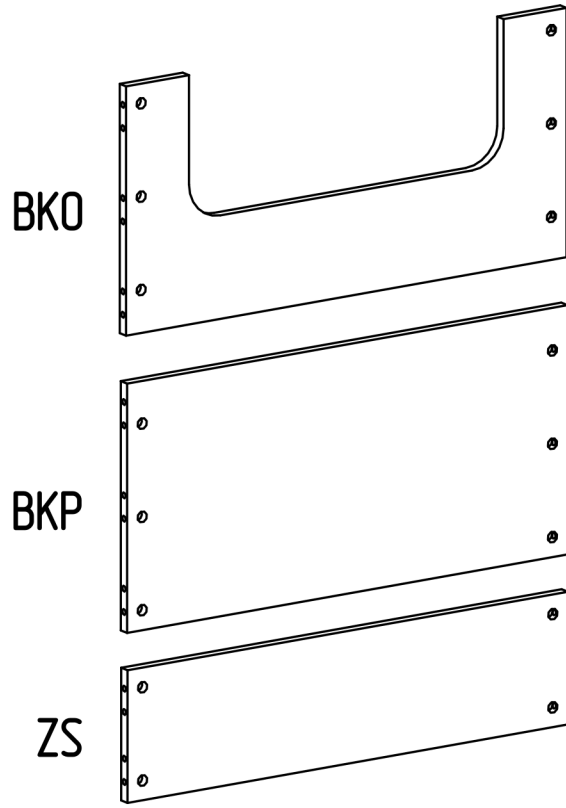

MIMI D

| | |
|------|--------|
| BKO | x4 |
| BKP | x4 |
| ZS | x2 |
| DR | x2 |
| SCH | x4 |
| LKS* | x8/x10 |
| ST | x28-32 |
| LDS | x8 |

*10x LKS - only for size 100

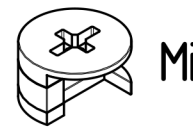
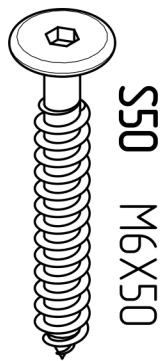
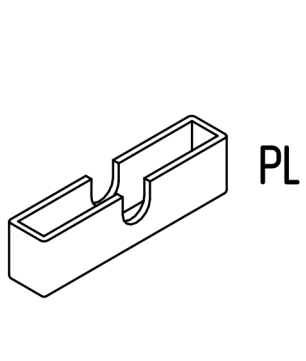

SCREWS Bed + drawer

| | |
|-----|--------|
| PL | x56-64 |
| S50 | x20 |
| W25 | x24 |
| TRZ | x108 |
| K8 | x120 |
| W13 | x25 |
| Mi | x108 |



The same situation for element

BGP

BDP

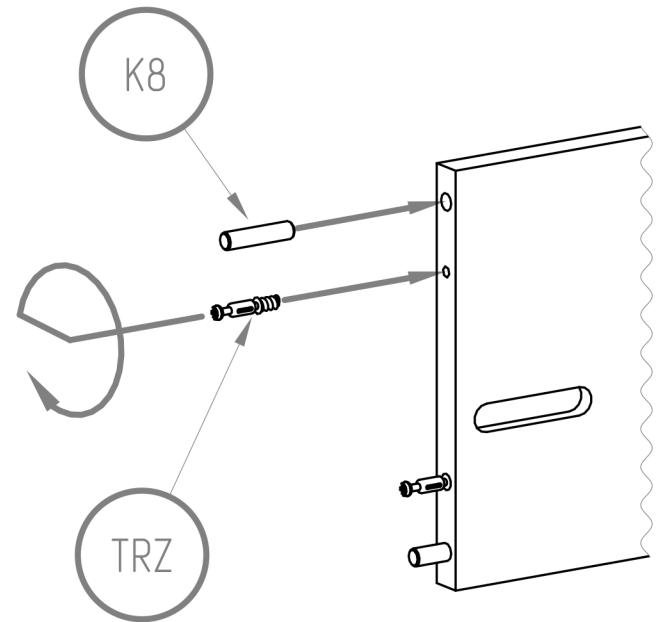
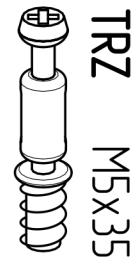
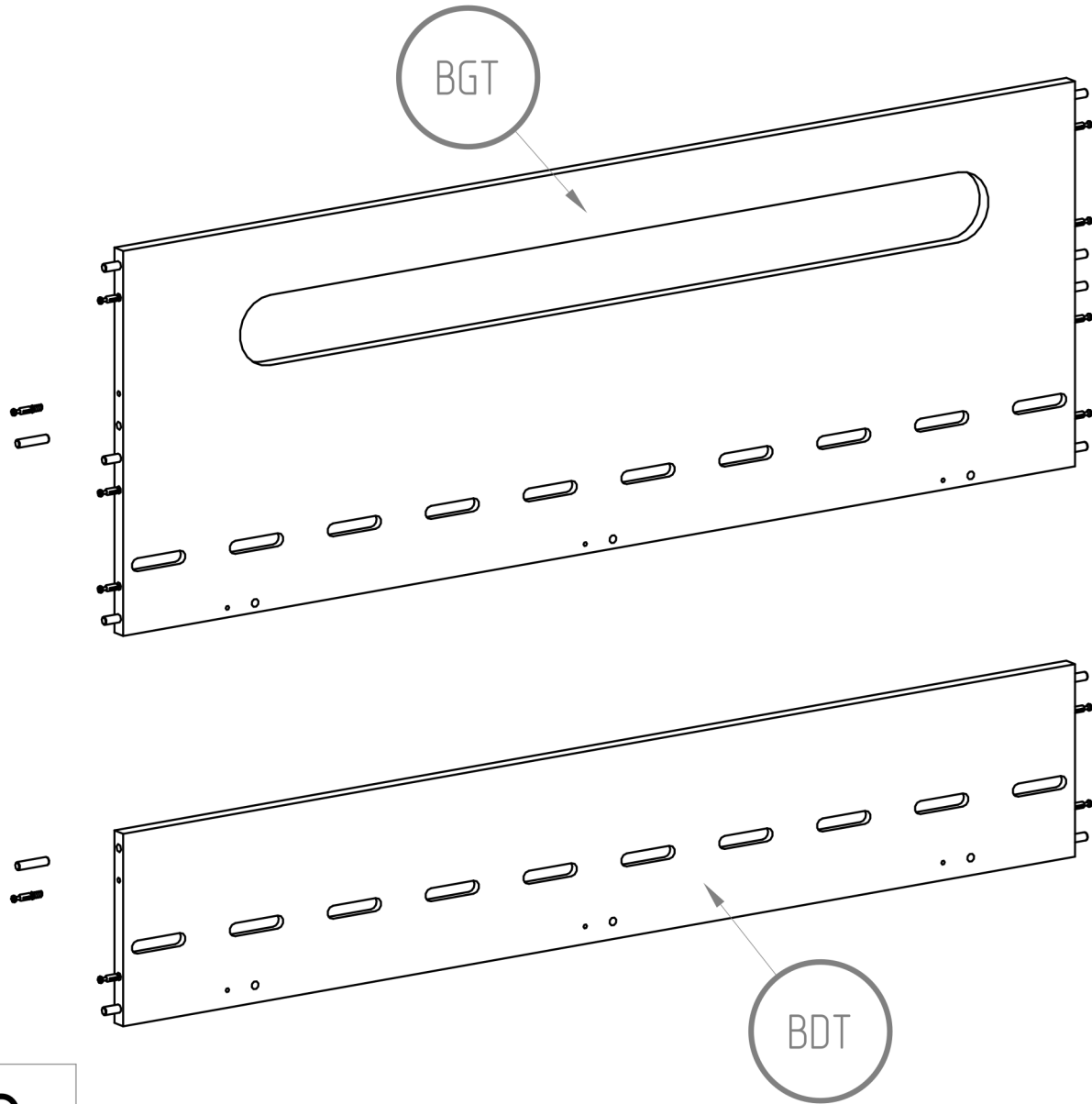

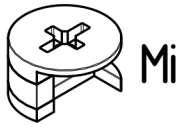

Recommendation

Assembly on the floor

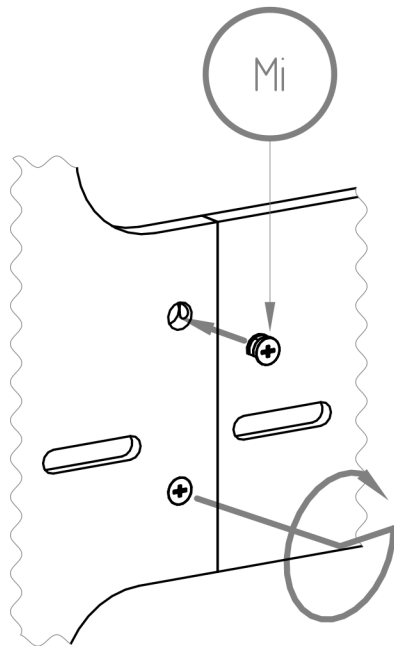
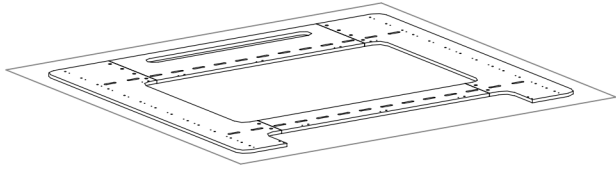

4



The same situation for element

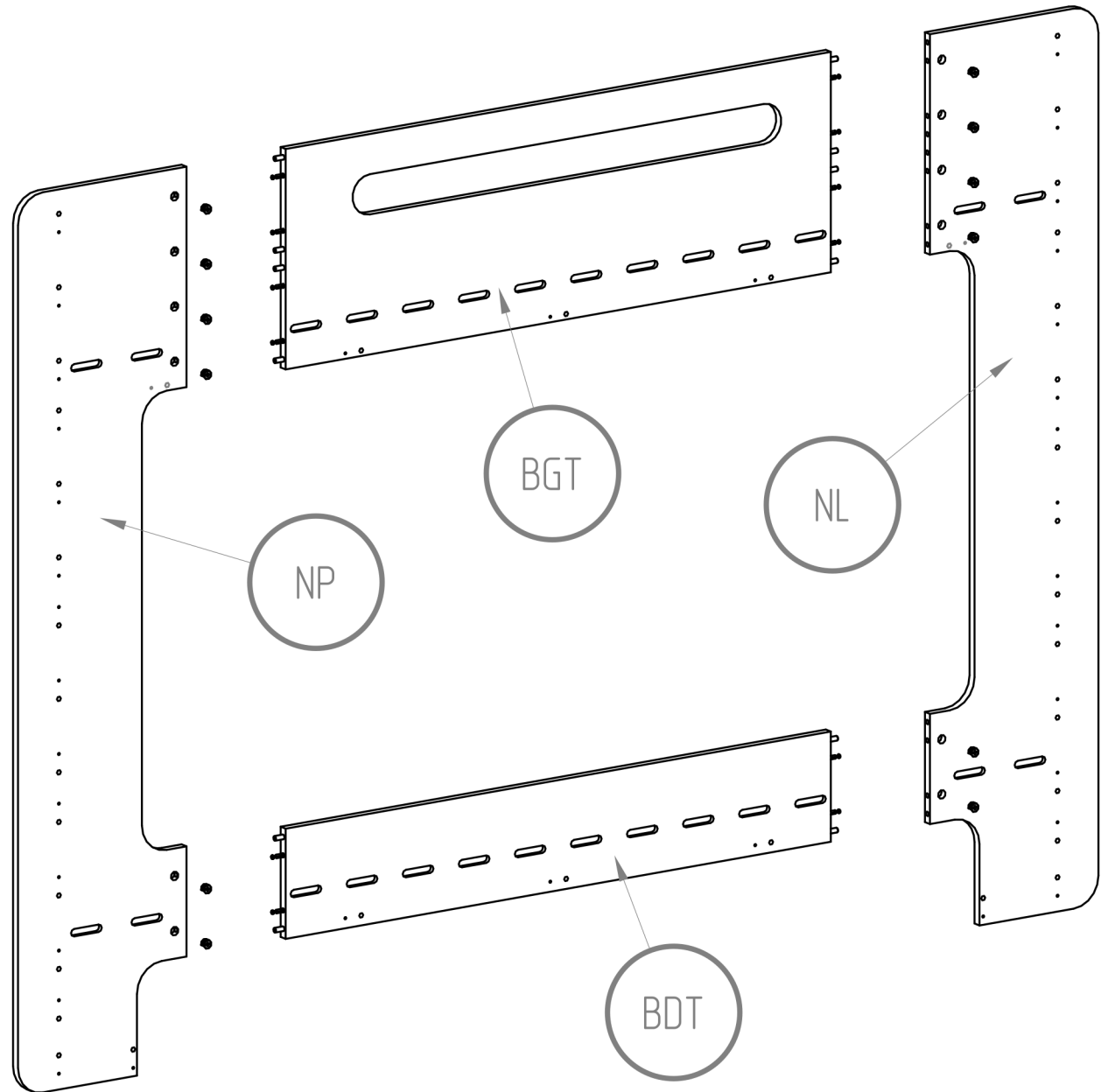

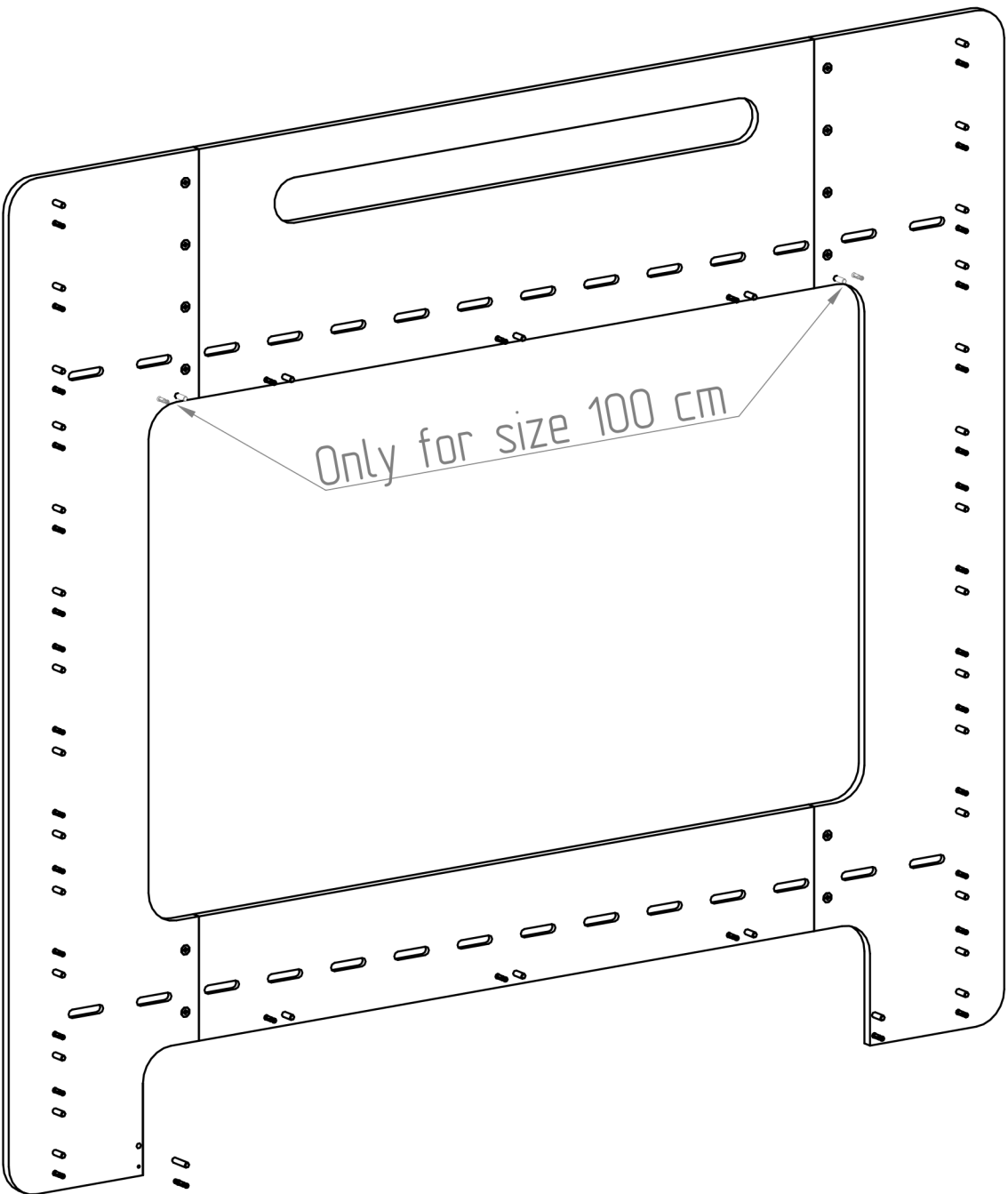
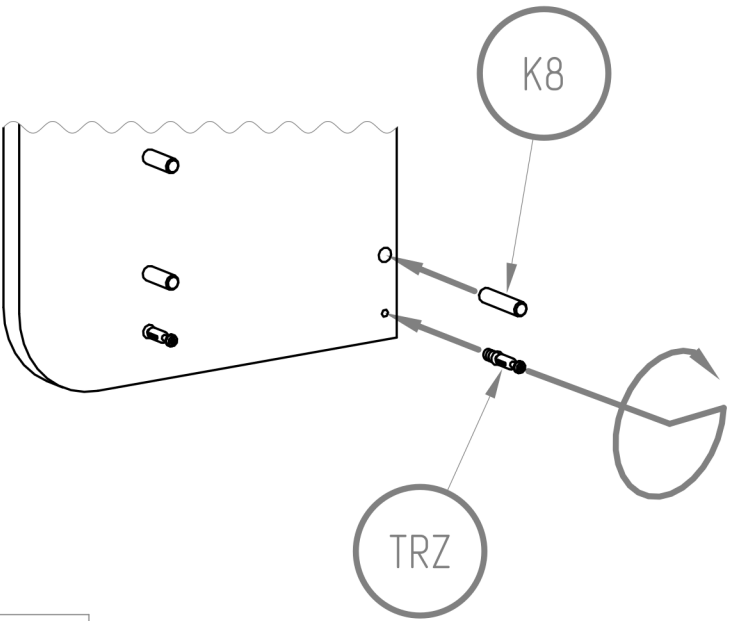

6

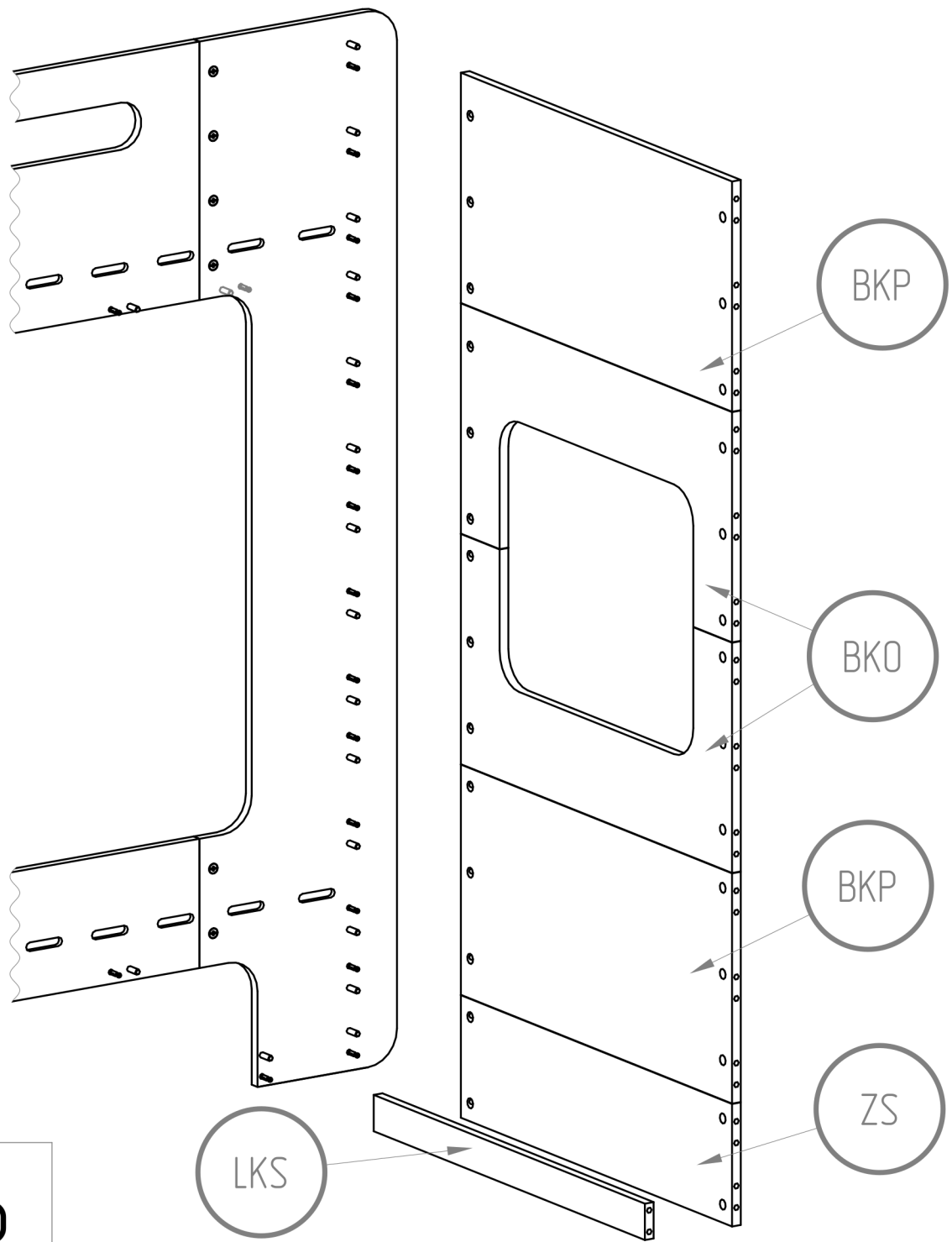

The same situation on the other side

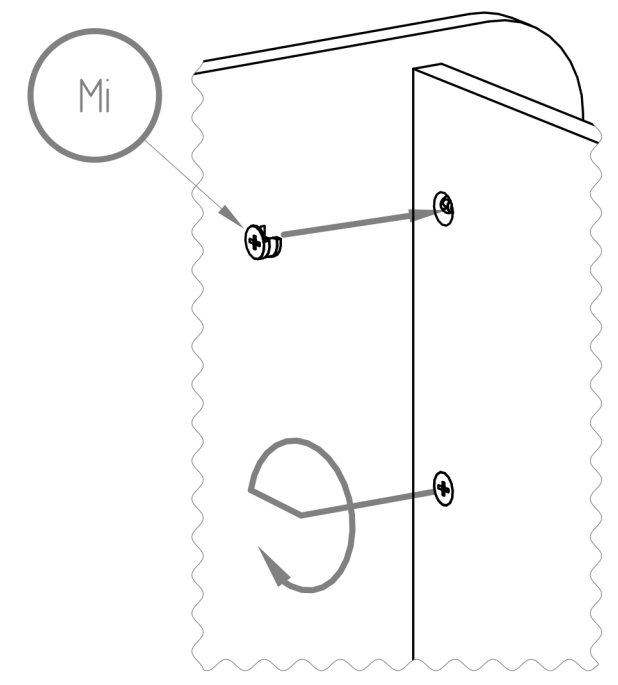
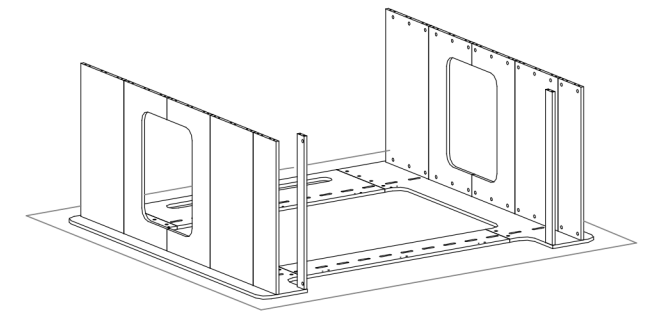

LKS

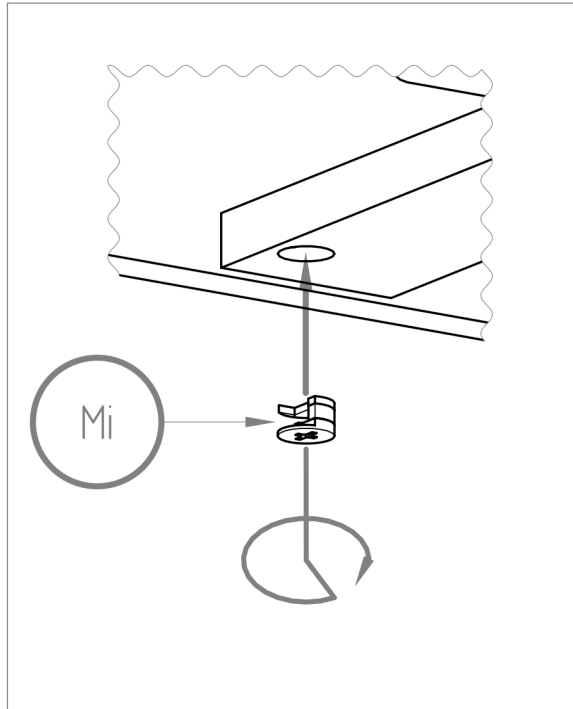
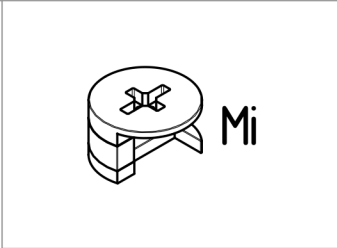
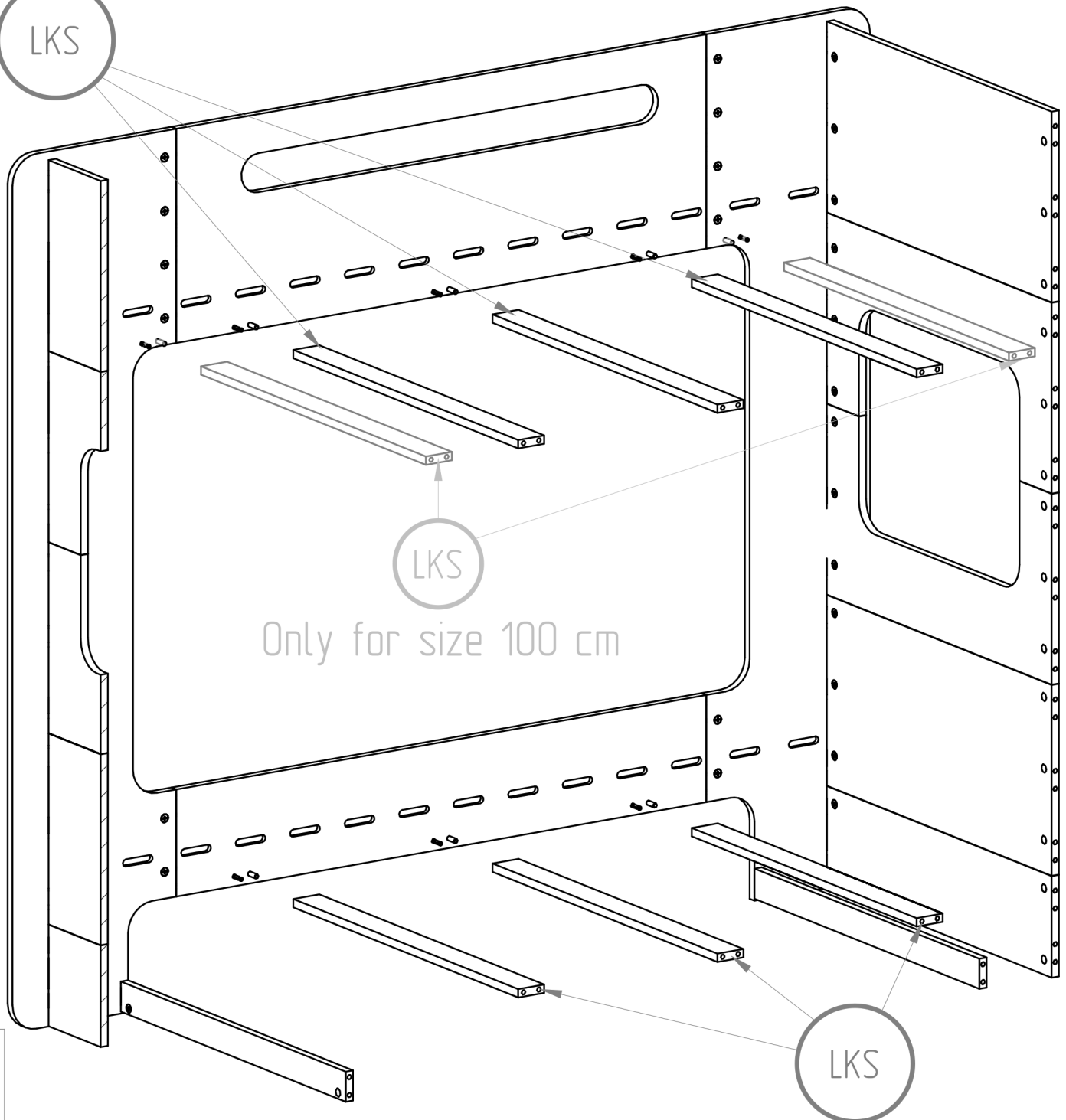

7

LKS



Before assembly, see pages 4 and 5

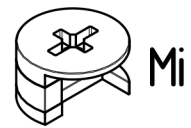
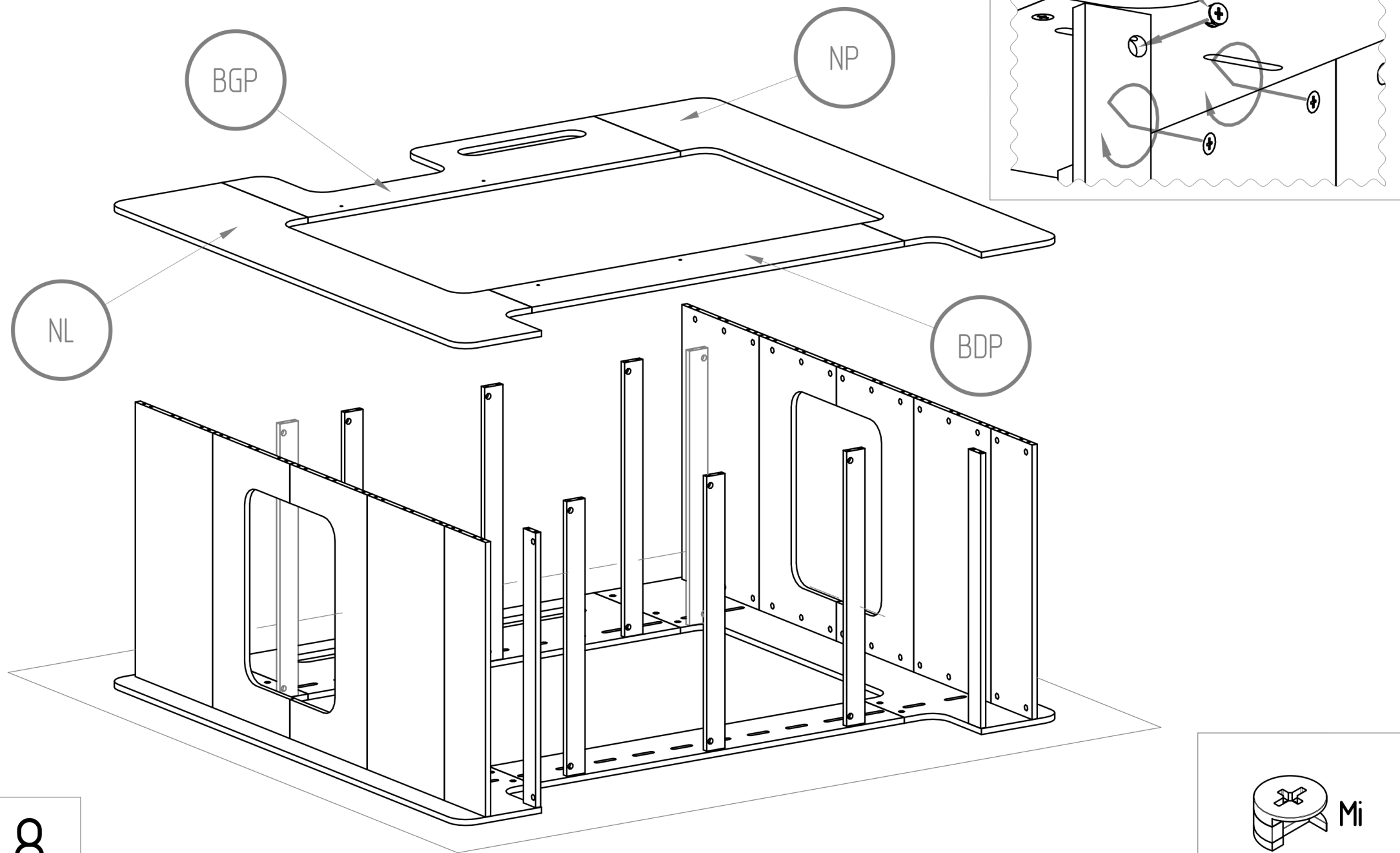

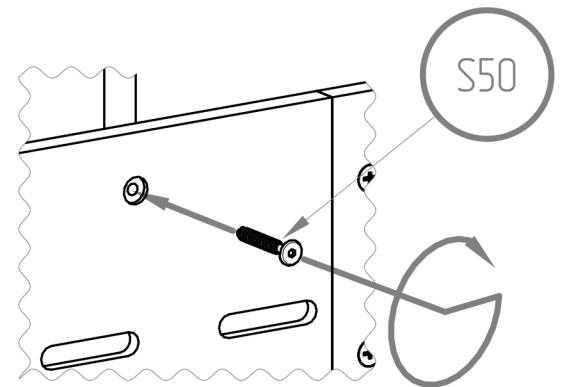
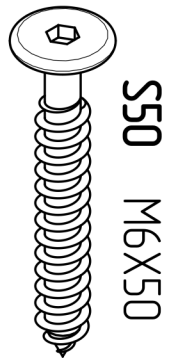
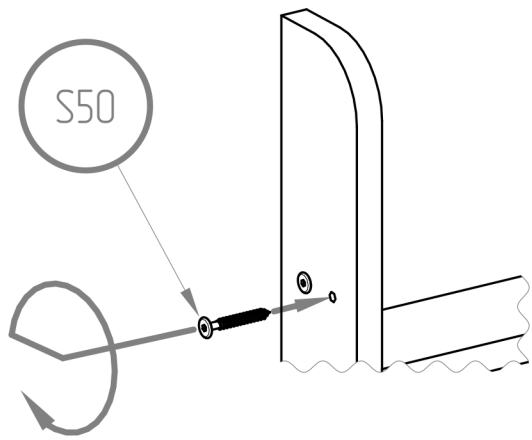
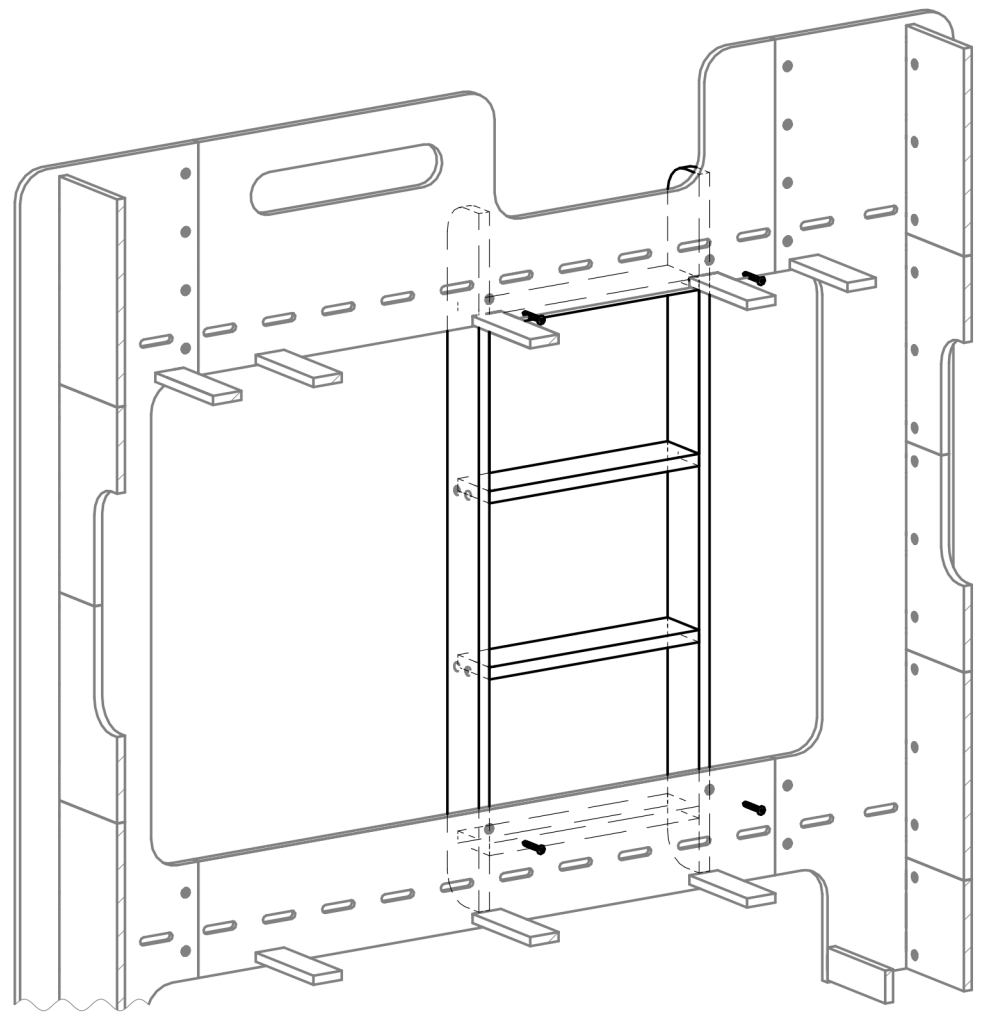
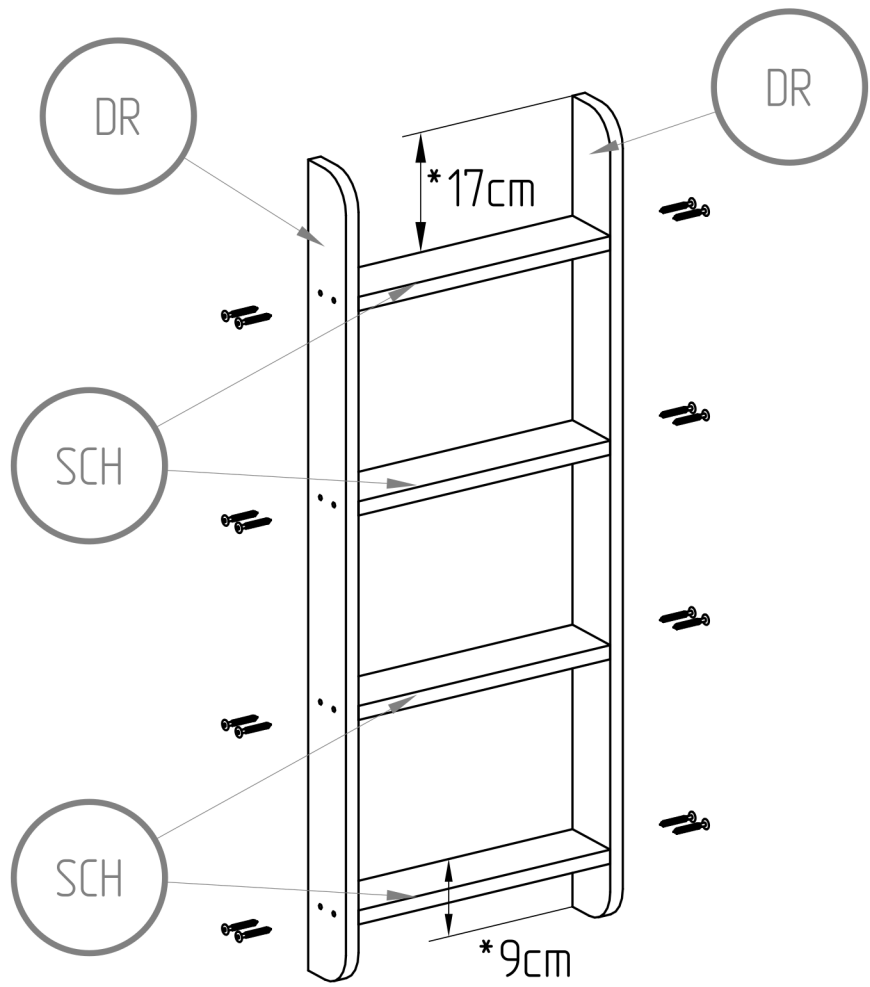

W25 M4X25

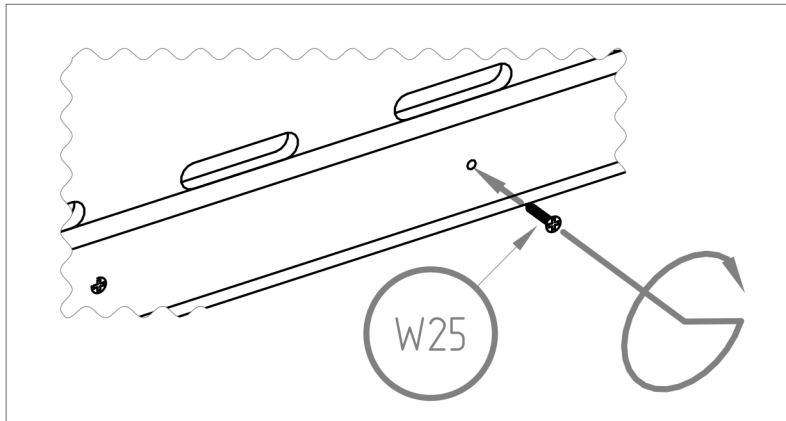
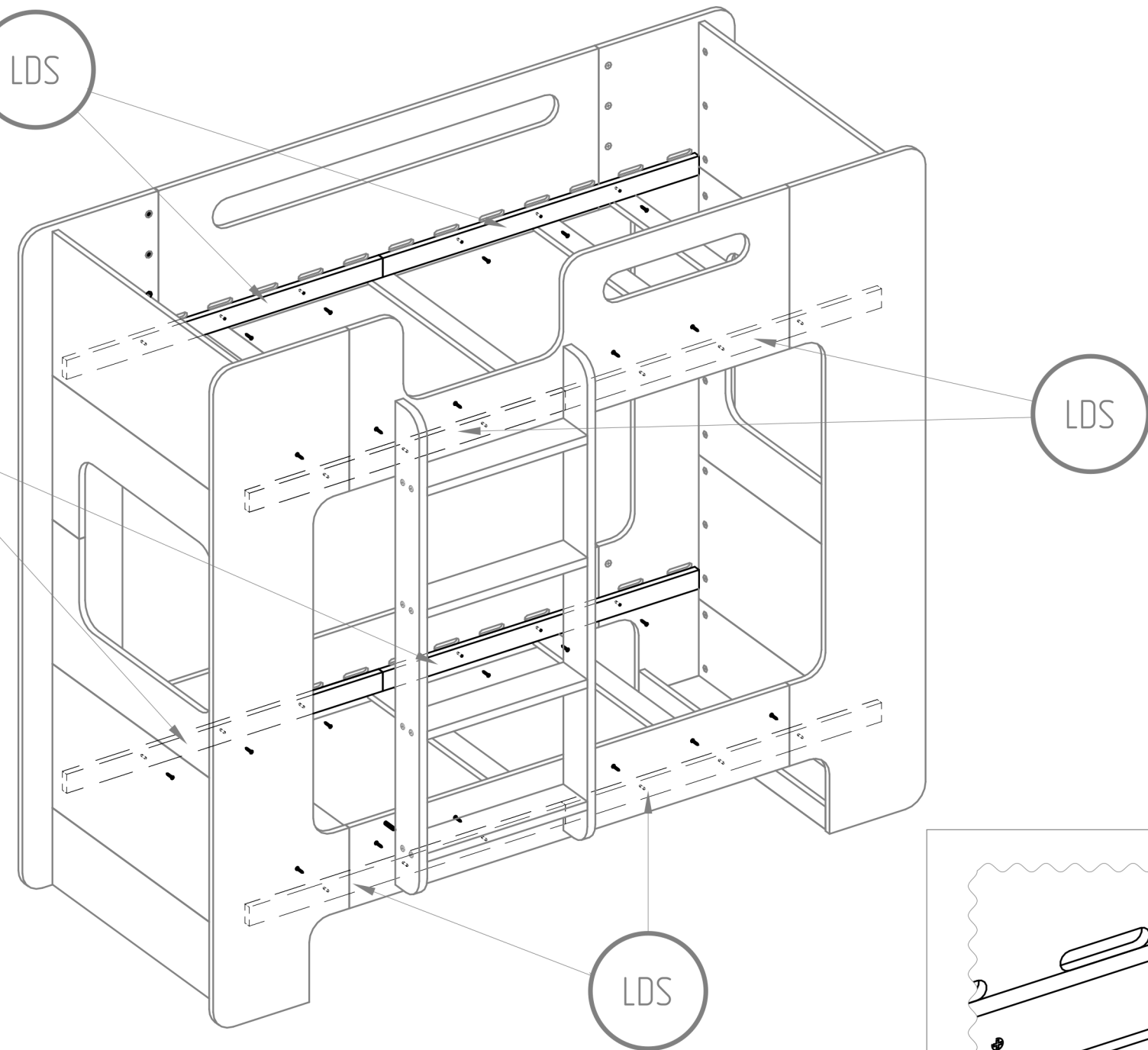

10

Important!

Install the plastic caps before assembling the ST spring slats to the bed frame.

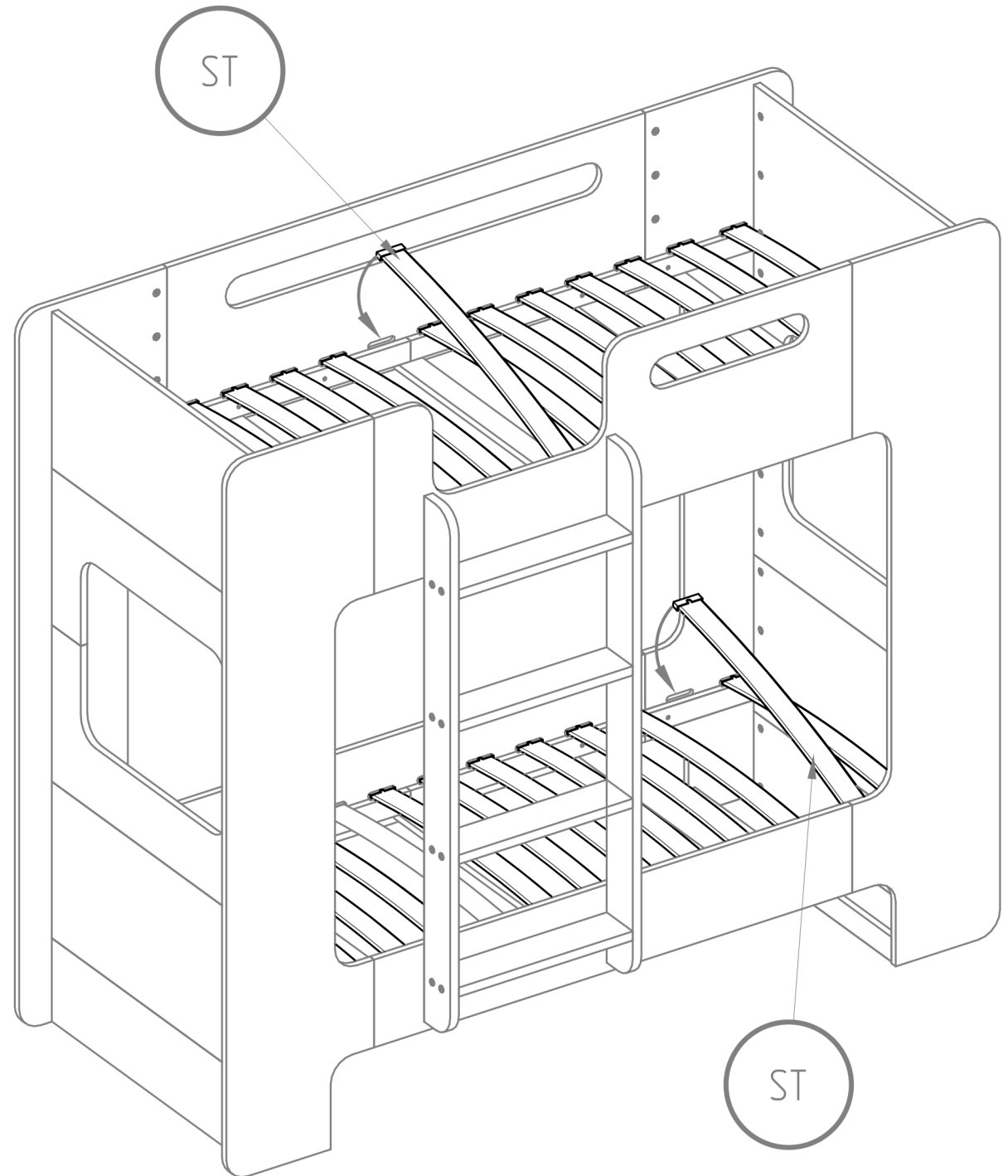
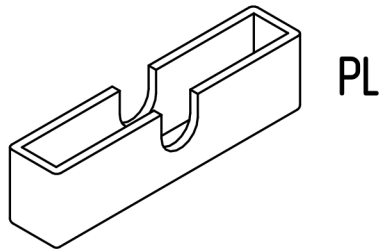
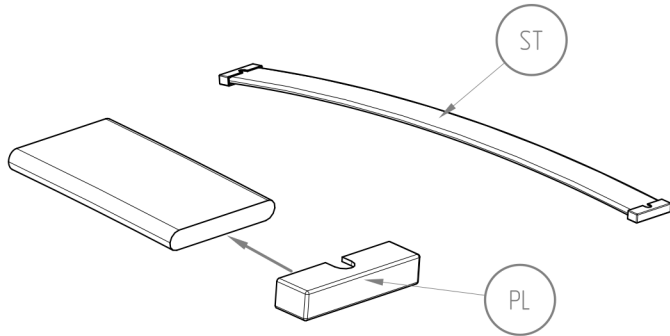

Attach these elements to both sides of the bed.

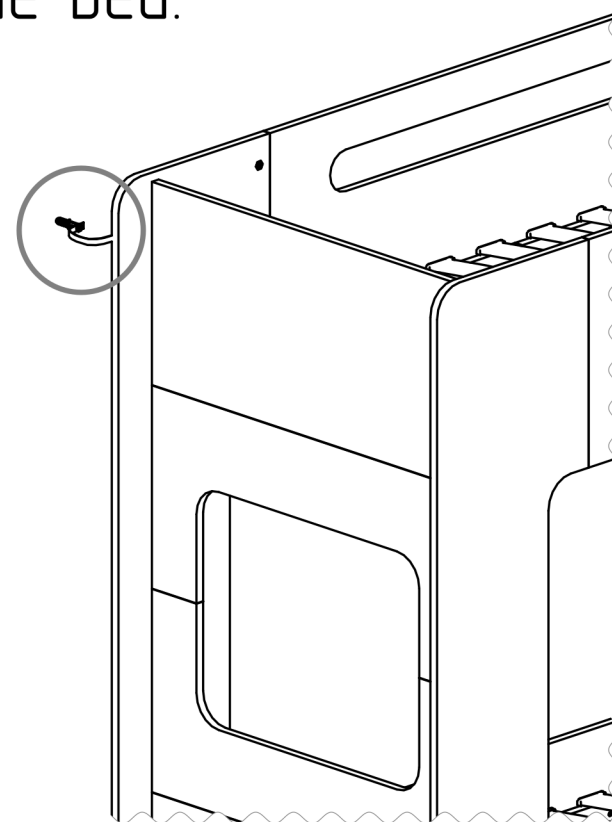
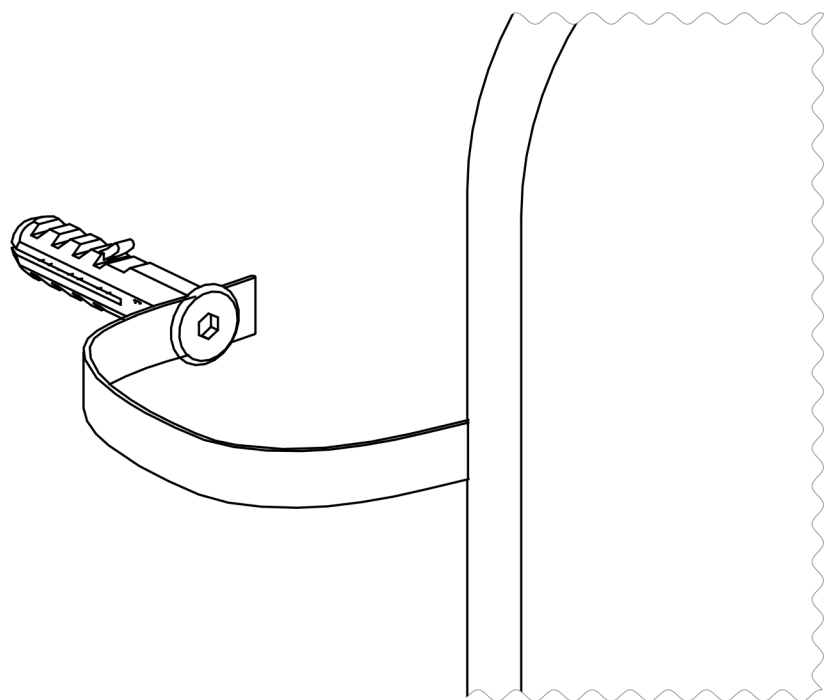

IMPORTANT!

High bed, risk of tipping over.

For safety, attach the bed to the wall using the provided safety elements.

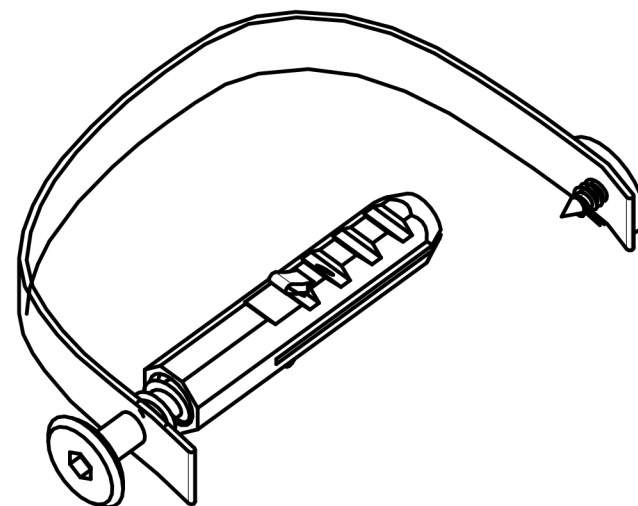

DRAWER

FOR SLEEPING

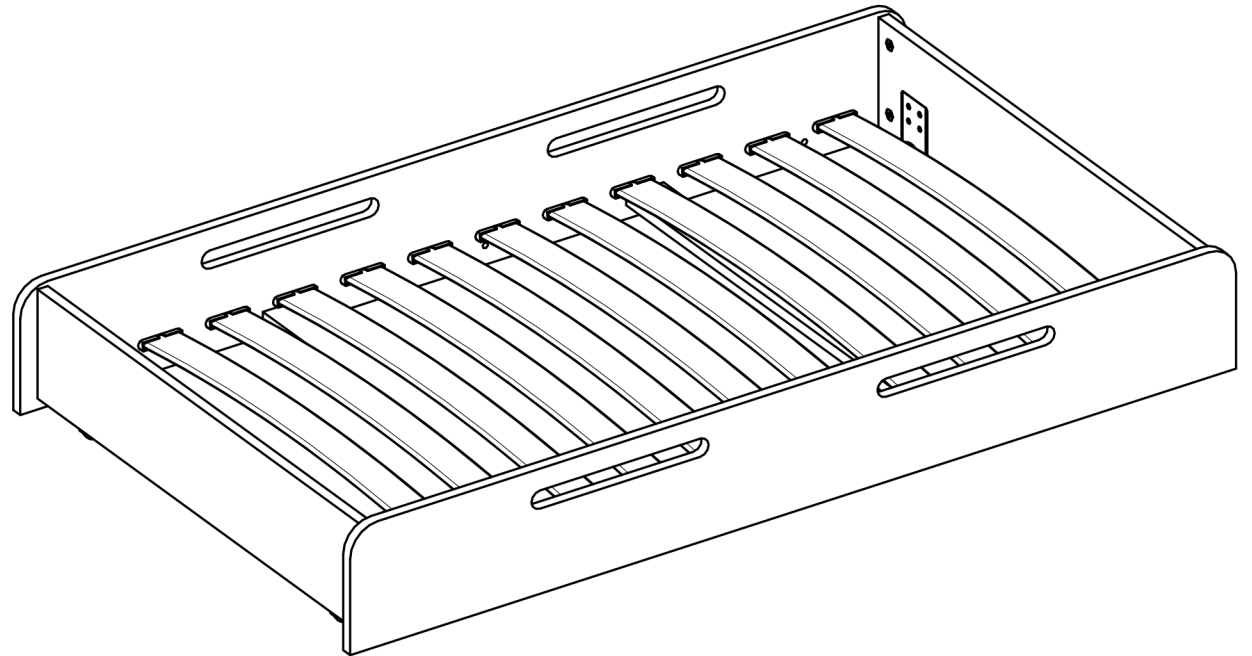

FOR STORAGE

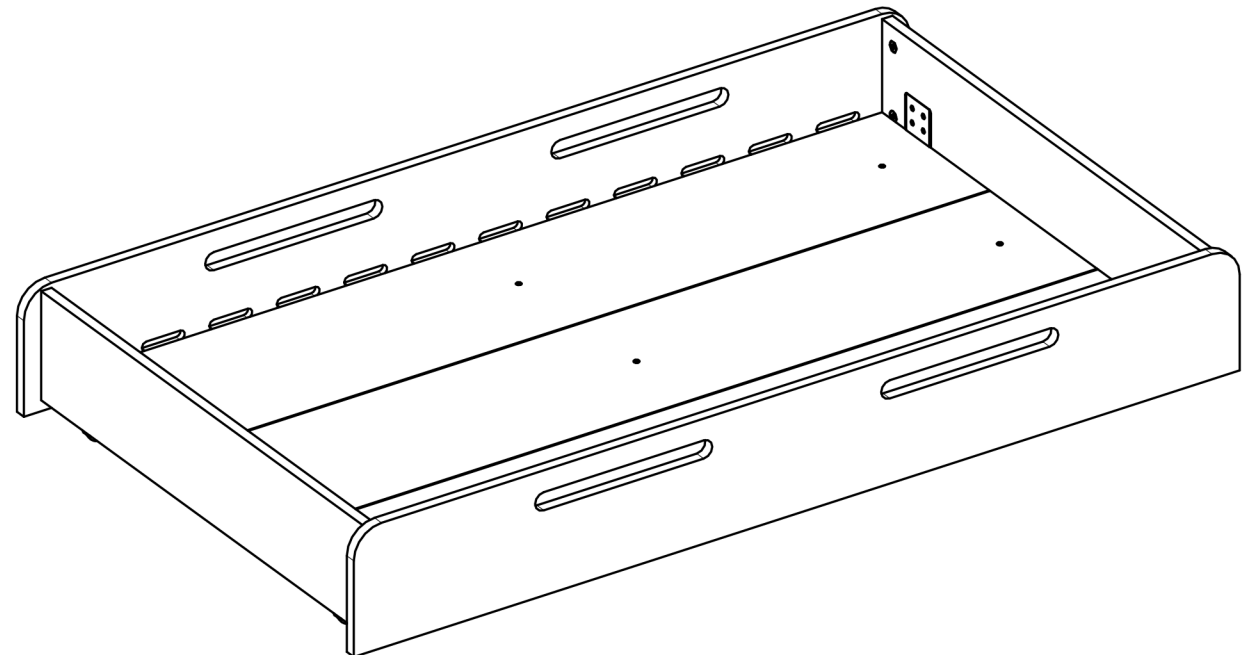

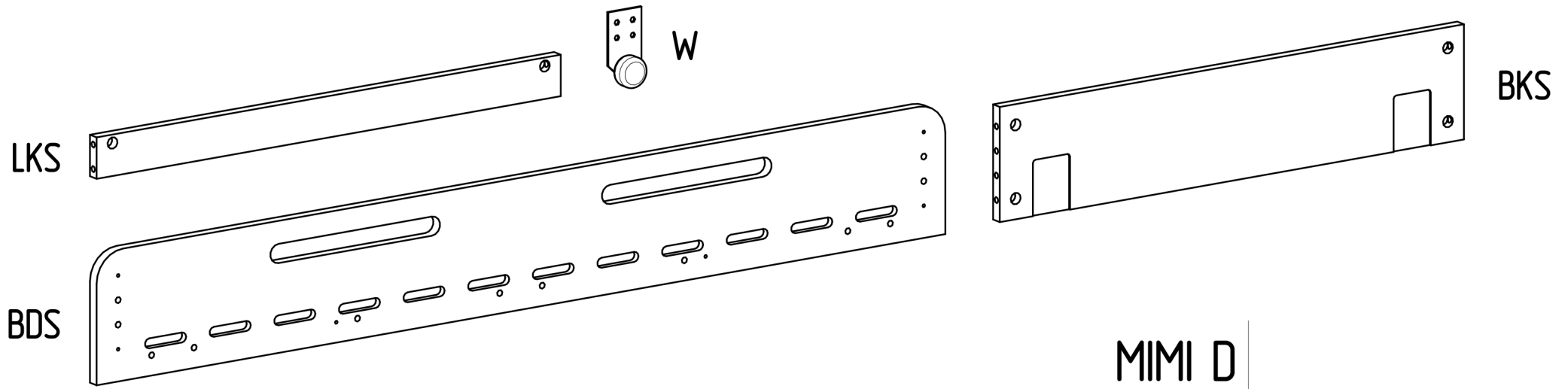

MIMI D

| | | | |
|-----|----|-----|----|
| BDS | x2 | LKS | x2 |
| BKS | x2 | W | x4 |

Depending on type of drawer, you will receive extra

Storage drawer

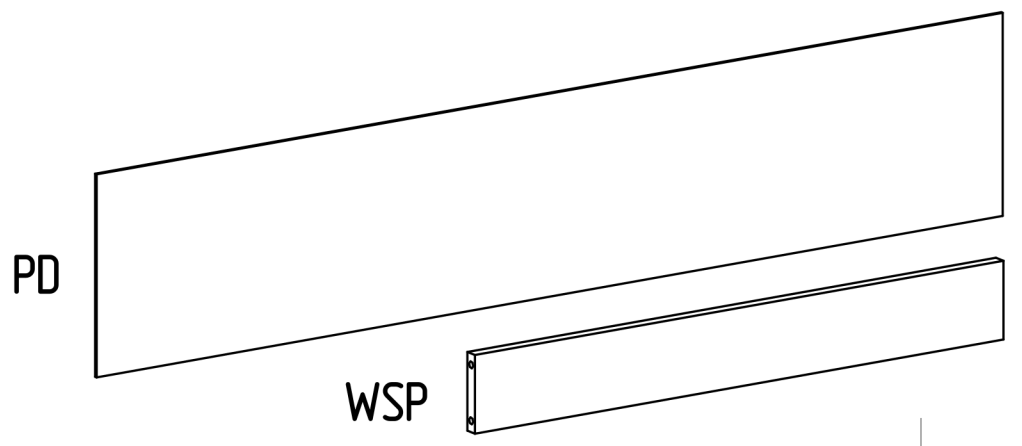

| | |
|-----|----|
| WSP | x3 |
| PD | x3 |

Sleeping drawer

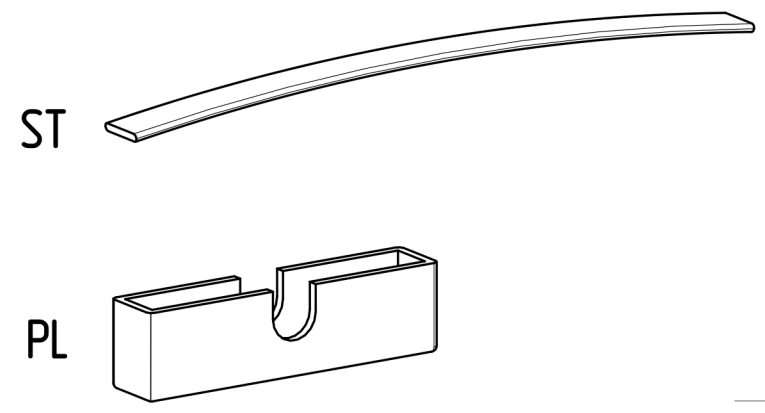

| | |
|----|--------|
| ST | x12-14 |
| PL | x24-28 |

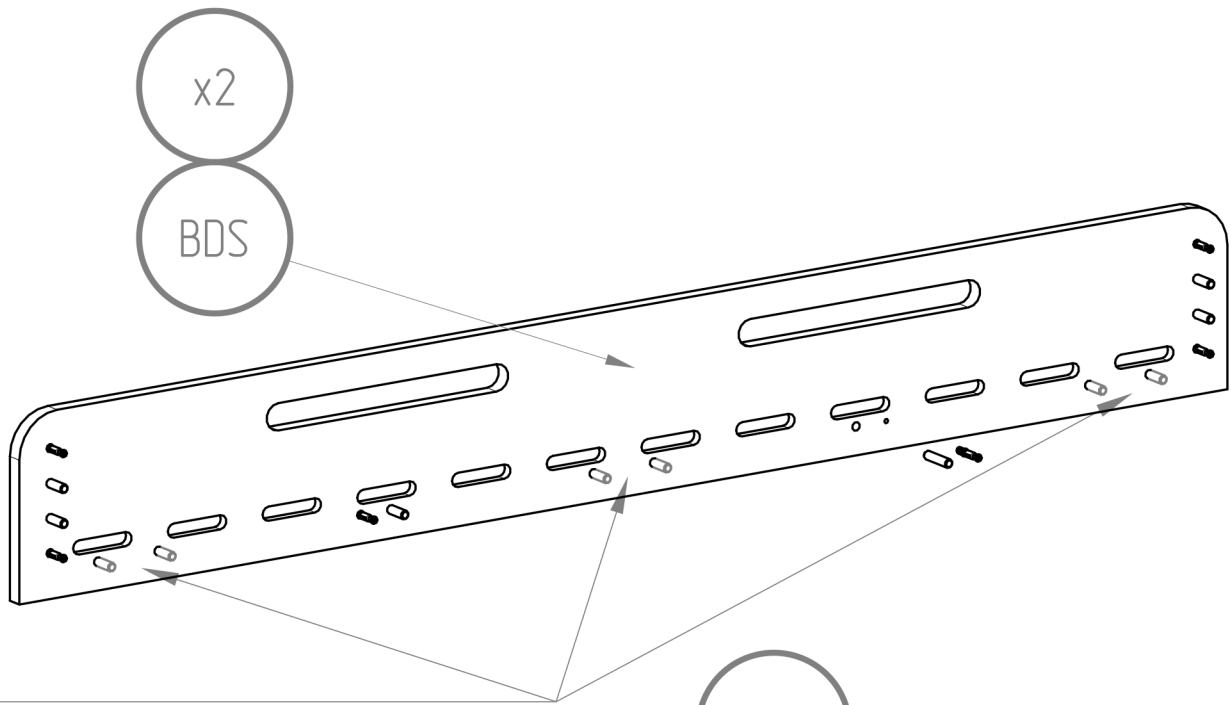

Only for storage drawer

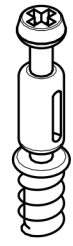
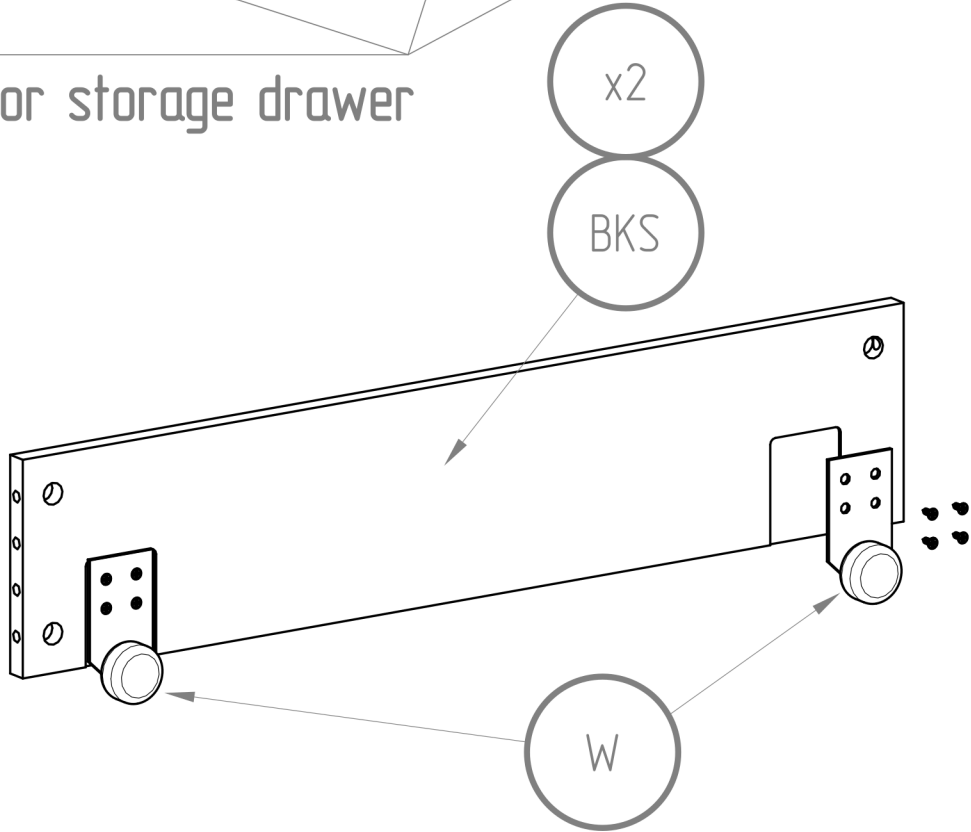

TRZ M5X35

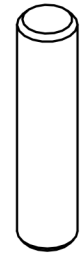

K8 M8X35



W13 M4X13

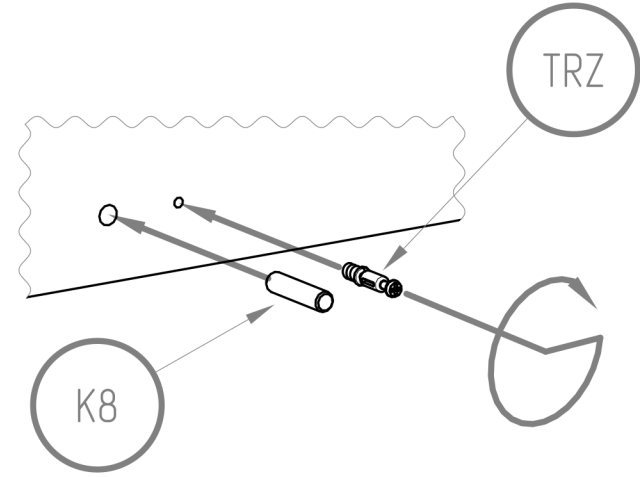

K8

TRZ

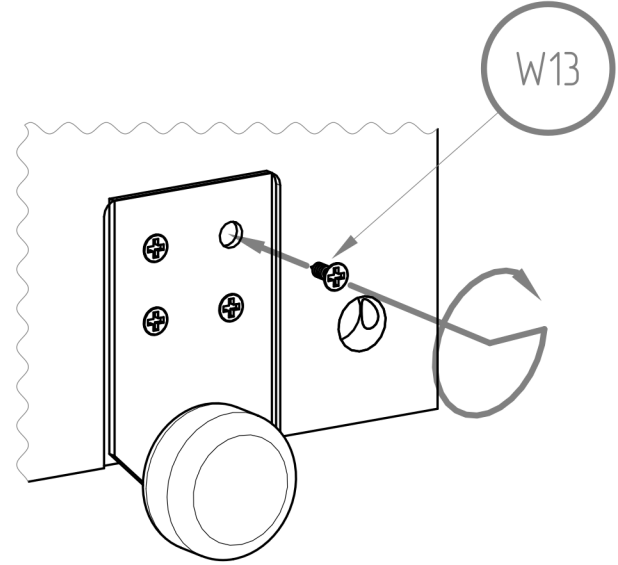

W13

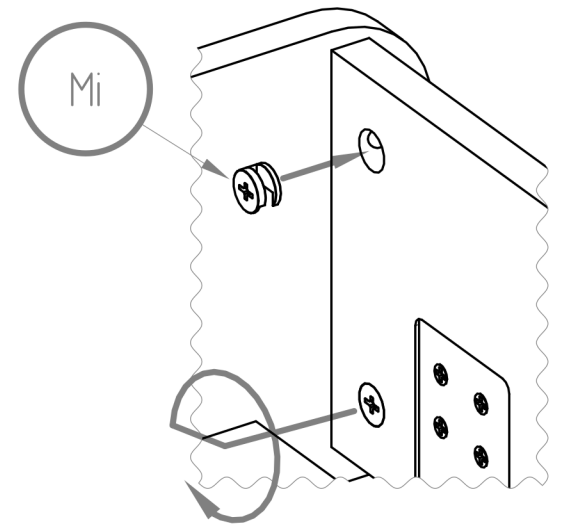
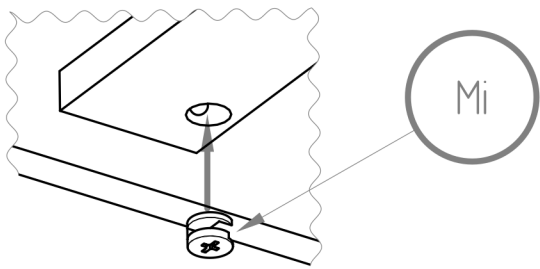

Only for storage drawer

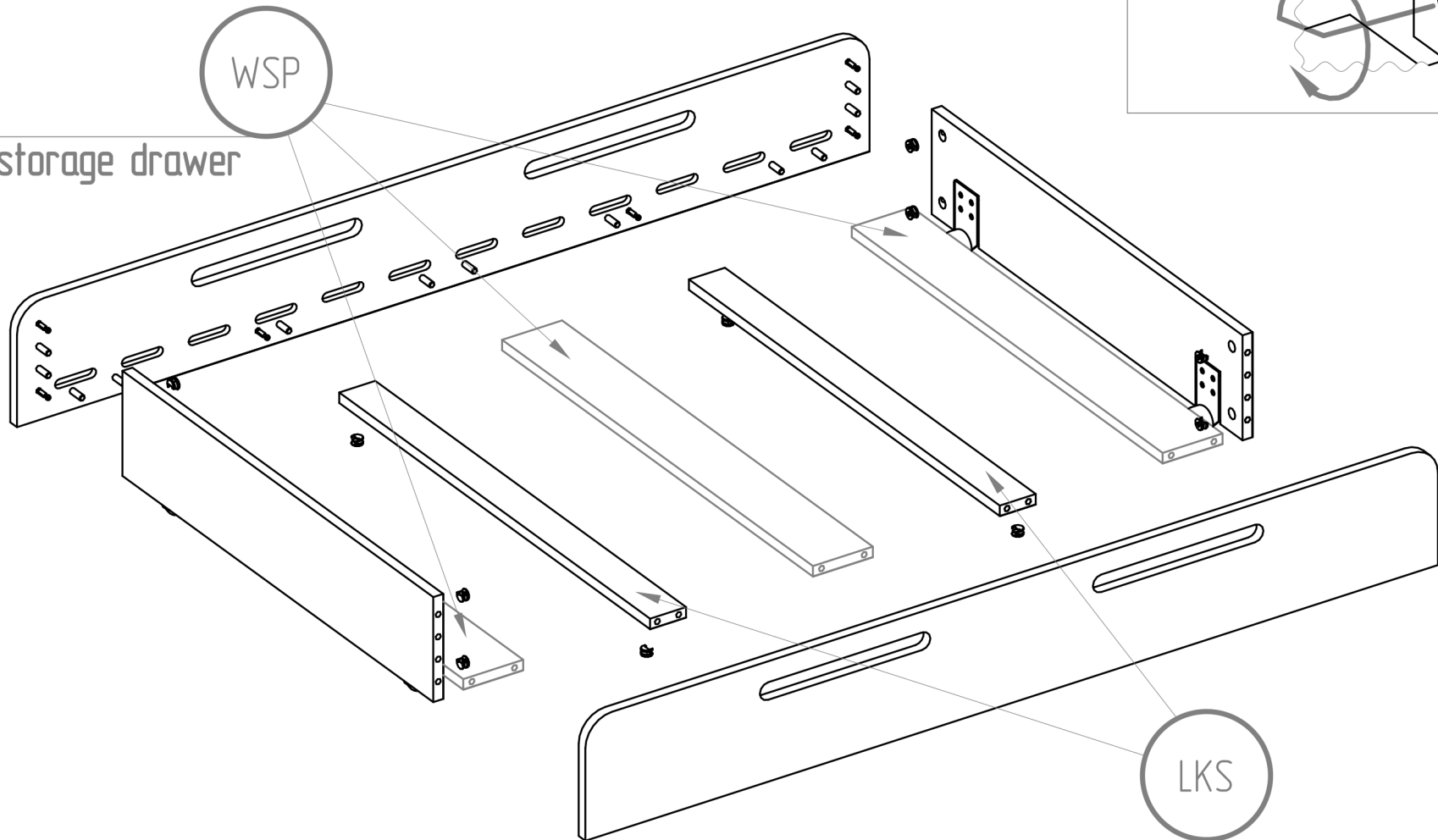

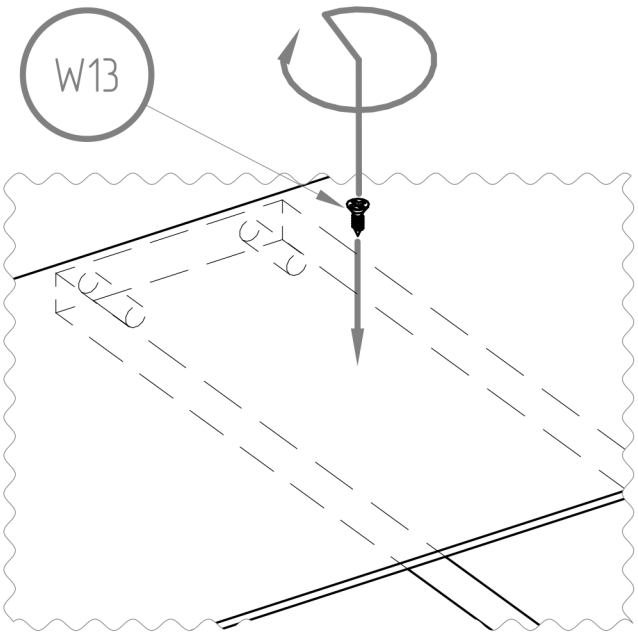

FOR STORAGE



W13 M4X13

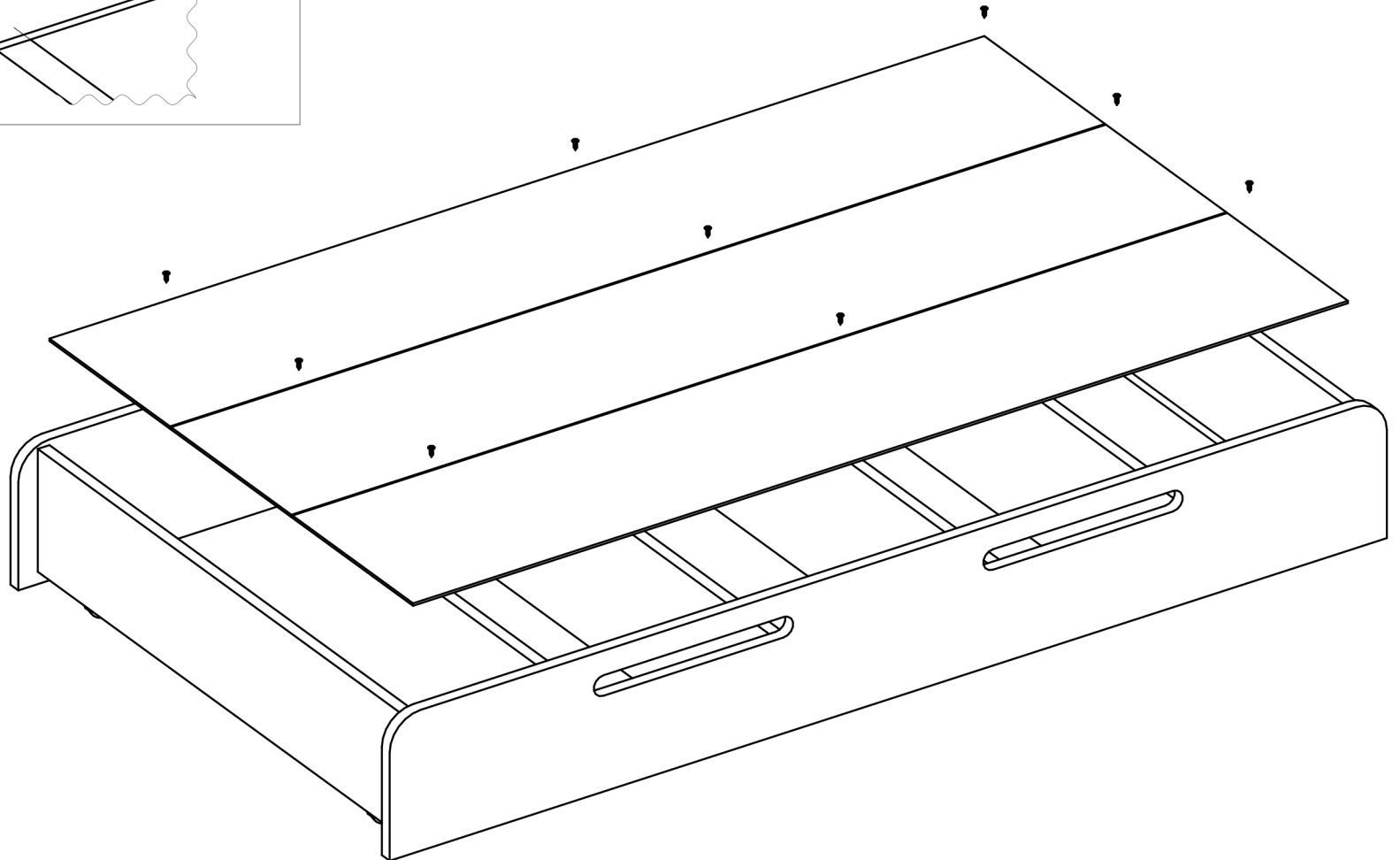

FOR SLEEPING

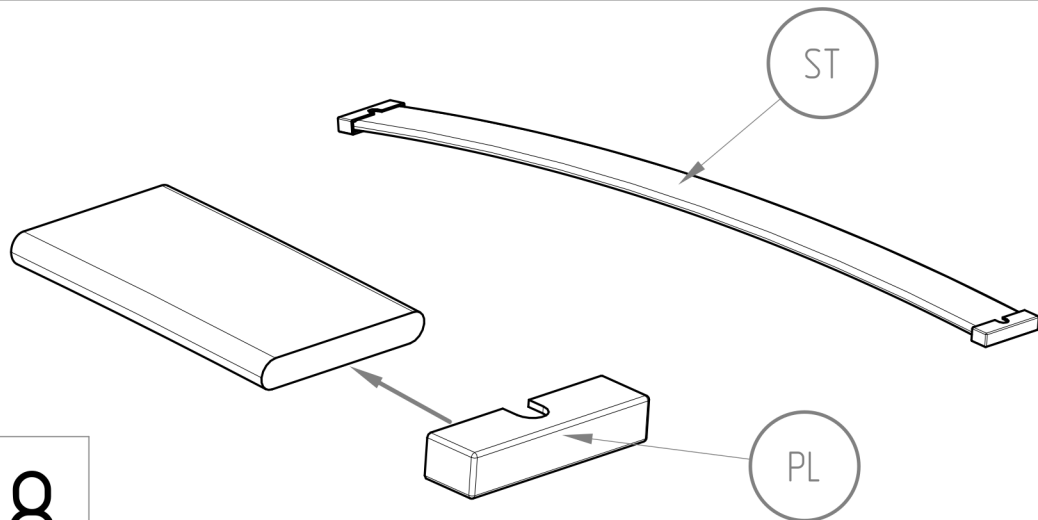
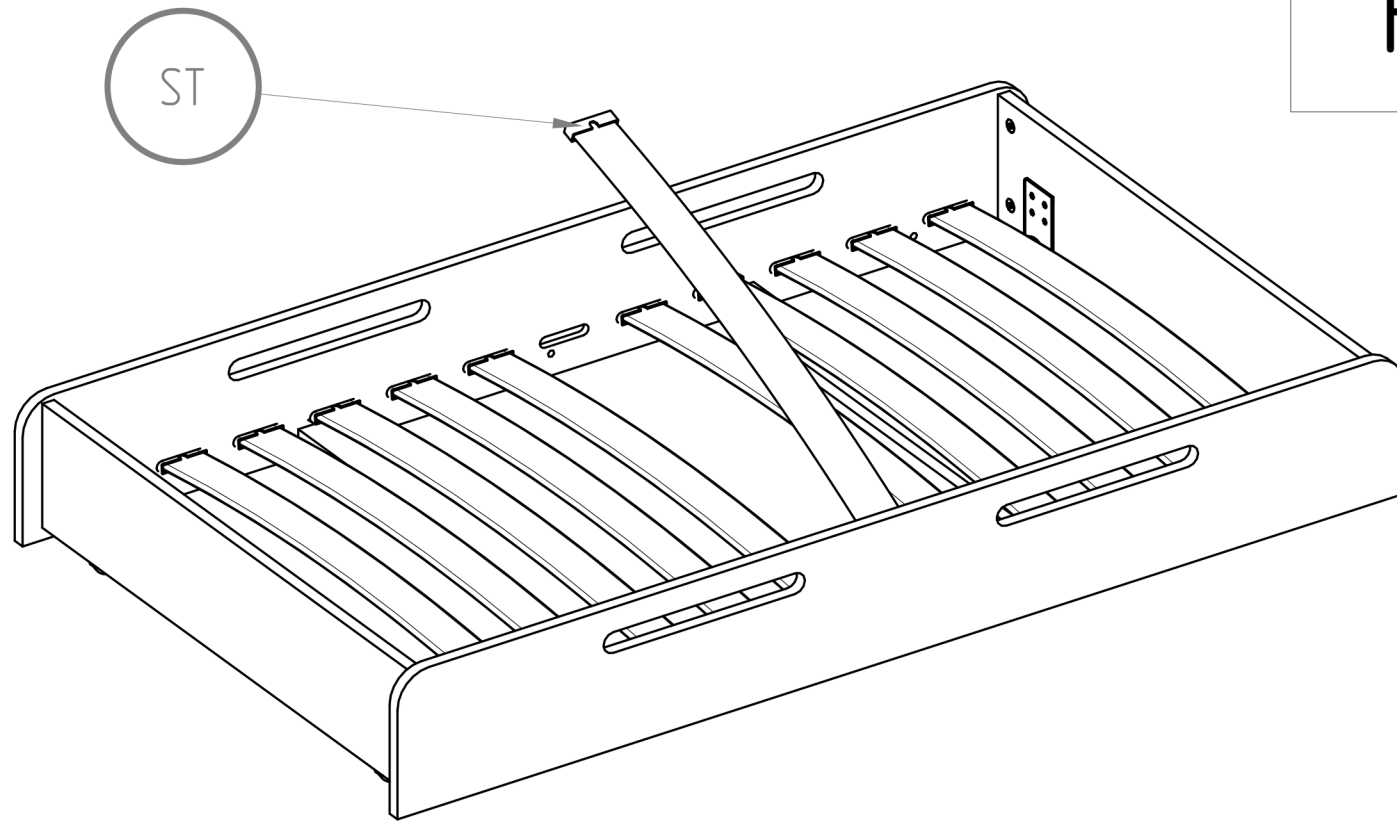

Important!

Install the plastic caps before assembling the ST spring slats to the bed frame.

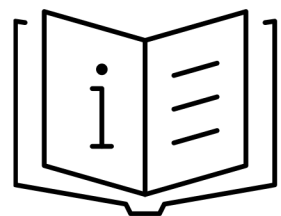

**UWAGA
WAŻNE**

**ATTENTION
IMPORTANT**

**ACHTUNG
WICHTIG**

**ATTENTION
IMPORTANTE**

**ATTENZIONE
IMPORTANTE**

**ATENCIÓN
IMPORTANTE**



Górne łóżko nie jest odpowiednie dla dzieci poniżej 6 roku życia.

The upper bed is not suitable for children under 6 years old.

Das obere Bett ist nicht für Kinder unter 6 Jahren geeignet.

Le lit supérieur n'est pas adapté aux enfants de moins de 6 ans.

Il letto superiore non è adatto ai bambini di età inferiore ai 6 anni.

La cama superior no es adecuada para niños menores de 6 años.



Max. grubość materaca to 12 cm. Rekomendujemy materace o grubości 8-12 cm. Wymiar materaca musi odpowiadać wymiarowi łóżka.

Max. mattress thickness is 12 cm. We recommend mattresses with a thickness of 8-12 cm. The mattress size must match the bed size.

Max. Matratzenstärke beträgt 12 cm. Wir empfehlen Matratzen mit einer Stärke von 8-12 cm. Die Matratzengröße muss der Bettgröße entsprechen.

Épaisseur maximale du matelas : 12 cm. Nous recommandons des matelas d'une épaisseur de 8 à 12 cm. La taille du matelas doit correspondre à la taille du lit.

Spessore massimo del materasso: 12 cm. Raccomandiamo materassi con uno spessore di 8-12 cm. Le dimensioni del materasso devono corrispondere alle dimensioni del letto

Grosor máximo del colchón: 12 cm. Recomendamos colchones con un grosor de 8-12 cm. El tamaño del colchón debe coincidir con el tamaño de la cama.



Maksymalne obciążenie łóżka górnego: 130 kg, dolnego: 230 kg.

Maximum load for the upper bed: 130 kg, lower bed: 230 kg.

Maximale Belastung für das obere Bett: 130 kg, untere Bett: 230 kg.

Charge maximale pour le lit supérieur: 130 kg, lit inférieur: 230 kg.

Carico massimo per il letto superiore: 130 kg, letto inferiore: 230 kg.

Carga máxima en la cama superior: 130 kg, cama inferior: 230 kg.

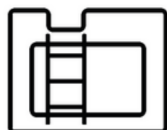

Używaj drabinki do wchodzenia na górne łóżko.

Use the ladder to climb to the upper bed.

Benutzen Sie die Leiter, um auf das obere Bett zu steigen.

Utilisez l'échelle pour monter sur le lit supérieur.

Usa la scala per salire sul letto superiore.

Usa la escalera para subir a la cama superior.



Zakaz skakania, zwłaszcza z górnej części łóżka.

No jumping, especially from the upper bed.

Kein Springen, insbesondere von der oberen Bett.

Interdiction de sauter, surtout depuis le lit supérieur.

Vietato saltare, soprattutto dal letto superiore.

Prohibido saltar, especialmente desde lo alto de la cama.

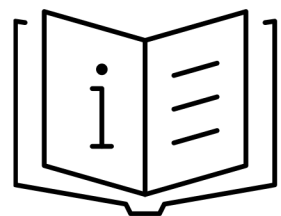

**UWAGA
WAŻNE**

Nie używaj łóżka, jeśli jakakolwiek jego część jest uszkodzona lub brakuje elementów.

**ATTENTION
IMPORTANT**

Do not use the bed if any part is damaged or if there are missing components.

**ACHTUNG
WICHTIG**

Benutzen Sie das Bett nicht, wenn ein Teil beschädigt ist oder Teile fehlen.

**ATTENTION
IMPORTANTE**

N'utilisez pas le lit si une partie est endommagée ou si des éléments sont manquants.

**ATTENZIONE
IMPORTANTE**

Non utilizzare il letto se una parte è danneggiata o se mancano dei componenti.

**ATENCIÓN
IMPORTANTE**

No uses la cama si alguna parte está dañada o falta algún componente.



Regularnie sprawdzaj, czy wszystkie mocowania są dobrze dokręcone.

Regularly check that all fasteners are properly tightened.

Überprüfen Sie regelmäßig, ob alle Befestigungen gut angezogen sind.

Vérifiez régulièrement que tous les fixations sont bien serrées.

Controlla regolarmente che tutte le fissaggi siano ben stretti.

Revisa regularmente que todos los elementos de sujeción estén bien apretados.



Zawsze postępuj zgodnie z instrukcjami montażu i użytkowania producenta.

Always follow the manufacturer's assembly and usage instructions.

Befolgen Sie immer die Montage- und Gebrauchsanweisungen des Herstellers

Suivez toujours les instructions de montage et d'utilisation du fabricant.

Segui sempre le istruzioni di montaggio e utilizzo del produttore.

Siempre sigue las instrucciones de montaje y uso del fabricante.



Korzystaj wyłącznie z oryginalnych części zamiennych dostarczonych przez producenta.

Use only original spare parts supplied by the manufacturer.

Verwenden Sie nur originale Ersatzteile, die vom Hersteller geliefert werden.

Utilisez uniquement des pièces de rechange d'origine fournies par le fabricant.

Utilizza solo pezzi di ricambio originali forniti dal produttore.

Utiliza únicamente piezas de repuesto originales proporcionadas por el fabricante.



Zapewnij odpowiednią wentylację pomieszczenia, aby uniknąć pleśni.

Ensure proper ventilation in the room to avoid mold.

Sorgen Sie für eine angemessene Belüftung des Raumes, um Schimmel zu vermeiden.

Assurez une ventilation adéquate de la pièce pour éviter la moisissure.

Assicurati di ventilare adeguatamente la stanza per evitare la muffa.

Asegúrate de proporcionar una ventilación adecuada en la habitación para evitar el moho.



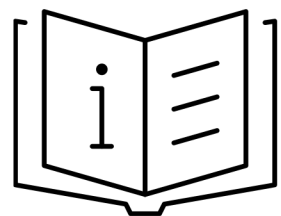

**UWAGA
WAŻNE**

**ATTENTION
IMPORTANT**

**ACHTUNG
WICHTIG**

**ATTENTION
IMPORTANTE**

**ATTENZIONE
IMPORTANTE**

**ATENCIÓN
IMPORTANTE**



Używaj tylko jednego materaca na każdej części łóżka.

Use only one mattress on each part of the bed.

Verwenden Sie nur eine Matratze auf jedem Teil des Bettes.

Utilisez uniquement un matelas sur chaque partie du lit.

Usa solo un materasso su ogni parte del letto.

Usa solo un colchón en cada parte de la cama.



Łóżka piętrowe i wysokie mogą stanowić ryzyko uduszenia. Nigdy nie mocuj ani nie wieszaj na nich przedmiotów, takich jak liny, sznurki itp.

Bunk beds and high beds can pose a suffocation risk. Never attach or hang items such as ropes, strings, etc., on them.

Etagenbetten und Hochbetten können ein Erstickungsrisiko darstellen. Befestigen oder hängen Sie niemals Gegenstände wie Seile, Schnüre usw. daran.

Les lits superposés et les lits en hauteur peuvent présenter un risque d'étouffement. Ne fixez ni ne suspendez jamais d'objets tels que des cordes, des ficelles, etc. sur eux.

I letti a castello e i letti alti possono costituire un rischio di soffocamento. Non attaccare né appendere mai oggetti come corde, fili, ecc. su di essi.

Las literas y camas altas pueden suponer un riesgo de estrangulamiento. No fije ni cuelgue nunca en ellos objetos como cuerdas, cordeles, etc.



Dla bezpieczeństwa dziecka zachowaj odległość między górną barierką a sąsiednią konstrukcją – powinna być mniejsza niż 75 mm lub większa niż 230 mm.

For the child's safety, keep the distance between the top railing and the adjacent structure - it should be less than 75 mm or more than 230 mm.

Für die Kindersicherheit sollte der Abstand zwischen dem oberen Geländer und der angrenzenden Struktur weniger als 75 mm oder mehr als 230 mm betragen.

Pour la sécurité de l'enfant, la distance entre le garde-corps supérieur et la structure adjacente doit être inférieure à 75 mm ou supérieure à 230 mm.

Per la sicurezza del bambino, la distanza tra la ringhiera superiore e la struttura adiacente deve essere inferiore a 75 mm o superiore a 230 mm.

Para la seguridad del niño, la distancia entre el pasamanos superior y la estructura adyacente debe ser inferior a 75 mm o superior a 230 mm.



Nie umieszczaj łóżka blisko okien, zasłon ani żaluzji.

Do not place the bed near windows, curtains, or blinds.

Stellen Sie das Bett nicht in die Nähe von Fenstern, Vorhängen oder Jalousien.

Ne placez pas le lit près des fenêtres, des rideaux ou des stores.

Non posizionare il letto vicino a finestre, tende o persiane.

No coloques la cama cerca de ventanas, cortinas o persianas.

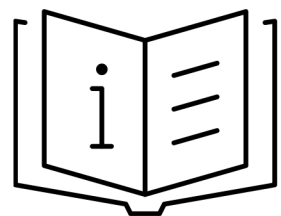

**UWAGA
WAŻNE**

**ATTENTION
IMPORTANT**

**ACHTUNG
WICHTIG**

**ATTENTION
IMPORTANTE**

**ATTENZIONE
IMPORTANTE**

**ATENCIÓN
IMPORTANTE**



Łóżko można czyścić środkami do pielęgnacji drewna lub delikatnie papierem ściernym, aby usunąć ewentualne zabrudzenia.

The bed can be cleaned with wood care products or gently with sandpaper to remove any dirt.

Das Bett kann mit Holzpflegeprodukten gereinigt oder mit Schleifpapier vorsichtig geschliffen werden, um Verschmutzungen zu entfernen.

Le lit peut être nettoyé avec des produits d'entretien du bois ou délicatement avec du papier de verre pour enlever la saleté.

Il letto può essere pulito con prodotti per la cura del legno o delicatamente con carta vetrata per rimuovere lo sporco.

La cama puede limpiarse con productos para el cuidado de la madera o suavemente con papel de lija para eliminar la suciedad.



Produkt musi być przymocowany do ściany lub innej konstrukcji.

The product must be attached to the wall or another structure.

Das Produkt muss an der Wand oder einer anderen Konstruktion befestigt werden.

Le produit doit être fixé au mur ou à une autre structure.

Il prodotto deve essere fissato al muro o a un'altra struttura.

El producto debe estar fijado a la pared o a otra estructura.



Części do łóżka objęte są 2-letnią gwarancją przy normalnym użytkowaniu.

The bed parts come with a 2-year warranty under standard use.

Auf die Bettteile wird eine Garantie von 2 Jahren gewährt bei normalem Gebrauch.

Les pièces du lit sont couvertes par une garantie de 2 ans en cas d'utilisation normale.

I componenti del letto sono coperti da una garanzia di 2 anni con un uso normale.

Las partes de la cama tienen una garantía de 2 años con un uso normal.



Łóżko zgodne z normą bezpieczeństwa EN 747-1:2024.

The bed complies with safety standard EN 747-1:2024.

Das Bett entspricht der Sicherheitsnorm EN 747-1:2024.

Le lit est conforme à la norme de sécurité EN 747-1:2024.

Il letto è conforme alla norma di sicurezza EN 747-1:2024.

La cama cumple con la norma de seguridad EN 747-1:2024.

ADDRESS

SMARTWOOD

Łazy 103a

37-550 Radymno

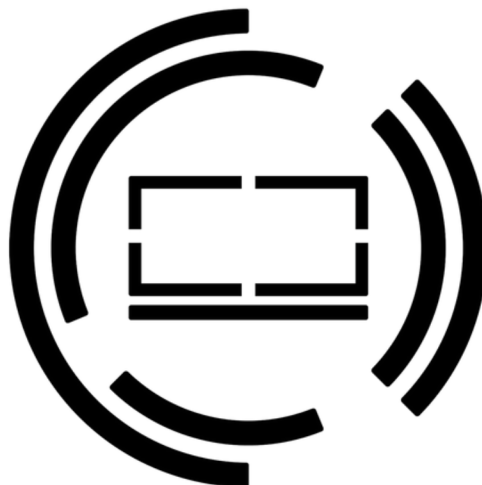

smartwood®

CONTACT

PL

shop@smartwood.pl

+48 535 982 922

ENG/DE/FR/IT/ES

*Support only in German and English

shop@smartwood.de

+49 160 98618205

smartwood.pl

smartwood.de

SCAN
ME

